

Engineering Specification

Job Name _____

Contractor _____

Job Location _____

Approval _____

Engineer _____

Contractor's P.O. No. _____

Approval _____

Representative _____

LEAD FREE*

Series LFFBV-3C-CC, LFFBVS-3C-CC

2-Piece, Full Port, Brass Ball Valves with 3/4" Hose End

Sizes: 1/2" and 3/4"

Series LFFBV-3C-CC ball valves are used in commercial and industrial wash down applications which require a 3/4" hose connection. These valves feature a bottom loaded blowout-proof stem, virgin PTFE seats, thrust washer and adjustable stem packing, chrome plated brass ball with brass cap and white polypropylene tether (chain). The LFFBV-3C-CC, LFFBVS-3C-CC features Lead Free* construction to comply with Lead Free* installation requirements.

Features

- Certified to NSF-61/G
- 400psi (28 bar) WOG
- Fluorocarbon elastomer stem O-ring
- Adjustable stem packing gland
- Virgin PTFE packing, thrust washer, and seat

Models

LFFBV-3C-CC 1/2" – 3/4" thread x 3/4" hose

LFFBVS-3C-CC 1/2" – 3/4" solder x 3/4" hose

Pressure Ratings

400psi (28 bar) WOG, non-shock

Temperature Range: 0°F to 400°F (-18°C to 204°C)**

*The wetted surface of this product contacted by consumable water contains less than 0.25% of lead by weight.

**Cap gasket is not suitable for temperatures above 200°F (93°C).



LFFBVS-3C-CC



LFFBV-3C-CC

Approvals

LFFBV-3C-CC, LFFBVS-3C-CC

Certified to NSF/ANSI Standard 61/G



Specifications

Approved valves shall be 2-piece full port design constructed of a forged Lead Free copper silicon alloy brass body and end adapter. Lead Free* 2-Piece, Full Port, Brass Ball Valves shall be constructed using Lead Free* materials. Lead Free* valves shall comply with state codes and standards, where applicable, requiring reduced lead content. Seats and stem packing shall be virgin PTFE. Stem shall be bottom loaded, blowout-proof design with fluorocarbon elastomer O-ring to prevent stem leaks. Valve to have an adjustable packing gland. Valves with double O-ring stem seal without adjustable packing are not acceptable. Brass cap with white polypropylene tether chain. Valve to be a Watts Series LFFBV-3C-CC or LFFBVS-3C-CC with 400psi (28 bar) WOG rating and NSF 61/G approval.

NOTICE

Not intended for use in throttling applications.

NOTICE

The information contained herein is not intended to replace the full product installation and safety information available or the experience of a trained product installer. You are required to thoroughly read all installation instructions and product safety information before beginning the installation of this product.

NOTICE

Inquire with governing authorities for local installation requirements

Materials

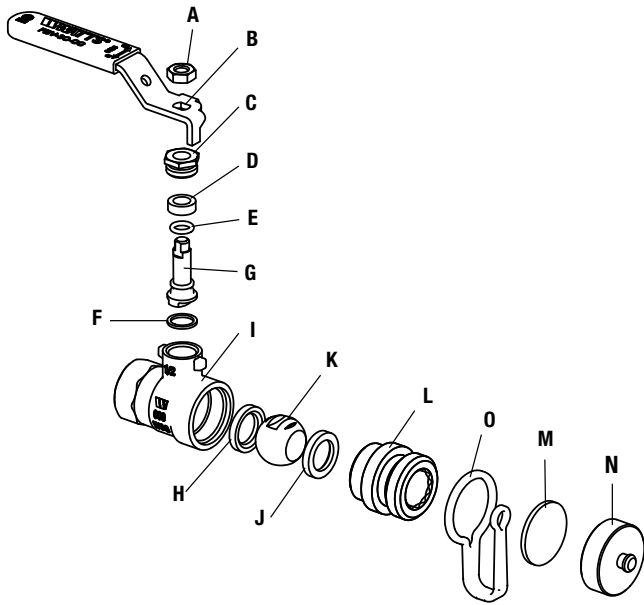

A	Handle nut	Zinc plated carbon steel
B	Handle	Zinc plated carbon steel with vinyl insulator
C	Packing Nut	Brass
D	Stem Packing	Virgin PTFE
E	O-ring	Fluorocarbon elastomer (FKM)
F	Thrust Washer	Virgin PTFE
G	Stem	Brass
H	Seat	Virgin PTFE
I	Body	Forged Lead Free* copper silicon alloy
J	Seat	Virgin PTFE
K	Ball	Chrome plated Lead Free* brass
L	Adapter	Forged Lead Free* copper silicon alloy
M	Gasket	Buna N
N	Cap	Brass
O	Cap Tether	Polypropylene - White

Dimensions

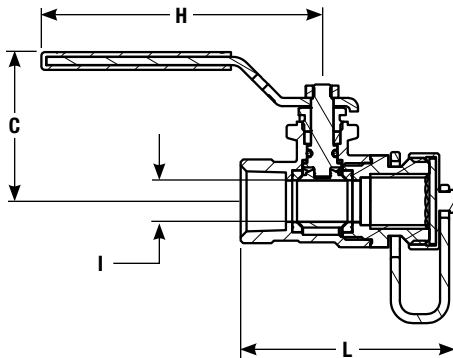

SIZE		MODEL		DIMENSIONS					
		C		H		I		L	
<i>in.</i>		<i>in.</i>	<i>mm</i>	<i>in.</i>	<i>mm</i>	<i>in.</i>	<i>mm</i>	<i>in.</i>	<i>mm</i>
1/2	FBV-3C-CC	1 ¹³ / ₁₆	46	3 ⁷ / ₁₆	87	1/2	13.0	2 ⁵ / ₈	67
3/4	FBV-3C-CC	2 ¹ / ₄	57	4	101	9/16	14.7	2 ¹⁵ / ₁₆	74
1/2	FBVS-3C-CC	1 ¹³ / ₁₆	46	3 ⁷ / ₁₆	87	1/2	13.0	2 ⁹ / ₁₆	66
3/4	FBVS-3C-CC	2 ¹ / ₄	57	4	101	9/16	14.7	3 ¹ / ₁₆	78

