

Installation and Operation Manual

Benchmark[®] Boilers With Edge[®] [ii] Controller

Natural Gas, Propane Gas and Dual Fuel
Modulating & Condensing Boilers

Models 750 through 6000

Other documents for this product include:

OMM-0137, Operation-Service Manual
OMM-0138, Reference Manual
OMM-0139, Edge Controller Manual
TAG-0019, Boiler Application Guide
TAG-0022, Vent-Combustion Air Guide
TAG-0047, Benchmark Gas Guide
TAG-0048, Benchmark Power Guide

Applies to serial numbers:

G-20-2773 and above – BMK750 – 5000N
N-20-0282 and above – BMK5000 & 6000



Disclaimer

The information contained in this document is subject to change without notice from AERCO International, Inc. AERCO makes no warranty of any kind with respect to this material, including, but not limited to, implied warranties of merchantability and fitness for a particular application. Some states do not allow the exclusion or limitation of incidental or consequential damages, so the above limitation may not apply. AERCO International is not liable for errors appearing in this document, not for incidental or consequential damages occurring in connection with the furnishing, performance, or use of these materials.



Contents

SECTION 1: SAFETY PRECAUTIONS.....	6
1.1 WARNINGS & CAUTIONS.....	6
1.2 EMERGENCY SHUTDOWN.....	7
1.3 PROLONGED SHUTDOWN.....	7
1.4 IMPORTANT – FOR MASSACHUSETTS INSTALLATIONS.....	8
SECTION 2: INSTALLATION	10
2.1 INTRODUCTION.....	10
2.2 RECEIVING THE UNIT.....	10
2.3 UNPACKING.....	10
2.4 SITE PREPARATION.....	11
2.4.1 Installation Clearances.....	11
2.4.2 Setting the Unit.....	14
2.4.3 Housekeeping Pad Requirements.....	17
2.5 LIFTING PROVISIONS.....	18
2.5.1 BMK750 – 1000 Lifting Provisions.....	18
2.5.2 BMK1500 – 5000N Lifting Provisions.....	19
2.5.3 BMK5000 & 6000 Lifting Provisions.....	19
2.6 SUPPLY AND RETURN PIPING.....	20
2.6.1 BMK750 – 1000 Supply and Return Piping.....	20
2.6.2 BMK1500 – 5000N Supply and Return Piping.....	20
2.6.3 BMK5000 – 6000 Supply and Return Piping.....	22
2.6.4 Dual Inlet Return Piping.....	22
2.7 WATER QUALITY – INITIAL SYSTEM FILL.....	23
2.8 PRESSURE RELIEF VALVE INSTALLATION.....	24
2.9 PRESSURE/TEMPERATURE GAUGE INSTALLATION.....	25
2.10 CONDENSATE DRAIN AND PIPING.....	25
2.11 GAS SUPPLY PIPING.....	29
2.11.1 Prior to installation.....	29
2.11.2 Gas Supply Specifications.....	29
2.11.3 External Gas Supply Regulator.....	29
2.11.4 Manual Gas Shutoff Valve.....	32
2.12 AC ELECTRICAL POWER WIRING.....	33
2.12.1 Electrical Power Requirements.....	33
2.12.2 Power Panel Locations.....	33
2.12.3 Electrical Power Panel Internal Components.....	34
2.13 FIELD CONTROL WIRING – I/O BOARD.....	35
2.13.1 I/O Board Connections.....	36
2.14 FLUE GAS VENT INSTALLATION.....	39
2.14.1 MASSACHUSETTS INSTALLATIONS.....	40
2.15 COMBUSTION AIR.....	40
2.15.1 DUCTED COMBUSTION AIR.....	40
2.16 BST SEQUENCING ISOLATION VALVE INSTALLATION.....	41
2.17 BOILER PUMP RELAY.....	43
2.18 NEXT STEPS.....	44
SECTION 3: ONAER SETUP	45
3.1 INTRODUCTION.....	45
3.1.1 Connecting the Ethernet Cable.....	46
3.1.2 Confirming the Ethernet Connection.....	46
3.1.3 Confirm Ethernet DHCP Configuration.....	47
APPENDIX A: DIMENSIONAL AND CLEARANCE DRAWINGS	48

FOREWORD

The AERCO Benchmark (BMK) 750 through 6000 natural gas and propane fueled boilers are modulating and condensing units. They represent a true industry advance that meets the needs of today's energy and environmental concerns. Designed for application in any closed loop hydronic system, the Benchmark's modulating capability relates energy input directly to fluctuating system loads. These BMK models provide extremely high efficiency operation and are ideally suited for modern low temperature, as well as, conventional heating systems.

IMPORTANT!
Unless otherwise specified: <ul style="list-style-type: none"> All descriptions in this document apply to the Benchmark Series of boiler. All measurements apply to both natural gas and propane models.

The Benchmark models operate within the input and output ranges listed below.

Benchmark Boiler Intake and Output Ranges				
MODEL	INPUT RANGE (BTU/HR.)		OUTPUT RANGE (BTU/HR.)	
	MINIMUM	MAXIMUM	MINIMUM	MAXIMUM
BMK750	50,000 (14.6 kW)	750,000 (220 kW)	47,750 (14.0 kW)	716,250 (210 kW)
BMK1000	50,000 (14.6 kW)	1,000,000 (293 kW)	48,300 (14.2 kW)	968,000 (284 kW)
BMK1500	75,000 (22 kW)	1,500,000 (440 kW)	64,500 (18.9 kW)	1,395,000 (409 kW)
BMK2000	100,000 (29.3 kW)	2,000,000 (586 kW)	86,000 (25.2 kW)	1,860,000 (545 kW)
BMK2500	167,000 (48.9 kW)	2,500,000 (732 kW)	144,000 (42.2 kW)	2,395,000 (702 kW)
BMK3000	200,000 (58.6 kW)	3,000,000 (879 kW)	174,000 (51.0 kW)	2,874,000 (842 kW)
BMK4000	267,000 (78.2 kW)	4,000,000 (1172 kW)	232,000 (68.0 kW)	3,800,000 (1113 kW)
BMK5000N	250,000 (73.3 kW)	4,990,000 (1462 kW)	218,000 (63.9 kW)	4,740,000 (1389 Kw)
BMK5000	400,000 (117 kW)	5,000,000 (1465 kW)	348,000 (102 kW)	4,750,000 (1392 kW)
BMK6000	400,000 (117 kW)	6,000,000 (1758 kW)	348,000 (102 kW)	5,700,000 (1670 kW)

The output of the boiler is a function of the unit's firing rate (valve position) and return water temperature.

When installed and operated in accordance with this Instruction Manual, the BMK750 – 2000 and 5000 & 6000 comply with the NO_x emission standards outlined in: **South Coast Air Quality Management District (SCAQMD), Rule 1146.2**. In addition, the BMK2500 – 6000 comply with the **Bay Area Air Quality Management District regulation 9, Rule 7**.

Whether used in singular or modular arrangements, the BMK boilers offer the maximum venting flexibility with minimum installation space requirements. These boilers are Category II and IV, positive pressure appliances. Single and/or multiple breeched units are capable of operation in the following vent configurations:

- Room Combustion Air:**
 - Vertical Discharge
 - Horizontal Discharge
- Ducted Combustion Air:**
 - Vertical Discharge
 - Horizontal Discharge

Please consult the *Benchmark Venting and Combustion Air Design Guide* (TAG-0022) for a list of allowable and preferred vent materials.

AERCO Technical Terminology Meanings	
TERMINOLOGY	MEANING
A (Amp)	Ampere
ACS	AERCO Control System, AERCO's boiler management systems
ADDR	Address
AGND	Analog Ground
ALRM	Alarm
ANSI	American National Standards Institute,
ASME	American Society of Mechanical Engineers
AUX	Auxiliary
BAS	Building Automation System, often used interchangeably with EMS (see below)
Baud Rate	Symbol rate, or simply the number of distinct symbol changes (signaling events) transmitted per second. It is not equal to bits per second, unless each symbol is 1 bit long.
BMK (Benchmark)	AERCO's Benchmark series boilers
BMS or BMS II	AERCO Boiler Management Systems
BLDG (Bldg)	Building
BST	AERCO on-board Boiler Sequencing Technology
BTU	British Thermal Unit. A unit of energy approximately equal to the heat required to raise 1 pound (0.45 kg) of water 1°F (0.55 °C)
BTU/HR	BTUs per Hour (1 BTU/hr = 0.29 W)
CCS	Combination Control System
C-More Controller	A control system developed by AERCO and currently used in all Benchmark, Innovation and KC1000 Series product lines.
CFH	Cubic Feet per Hour (1 CFH = 0.028 m ³ /hr.)
CO	Carbon Monoxide
COMM (Comm)	Communication
Cal.	Calibration
CNTL	Control
CPU	Central Processing Unit
DBB	Double Block and Bleed, a gas trains containing 2 Safety Shutoff Valves (SSOVs) and a solenoid operated vent valve.
DIP	Dual In-Line Package, a type of switch
ECU	Electronic Control Unit (O ₂ sensor)
EMS	Energy Management System; often used interchangeably with BAS
FM	Factory Mutual. Used to define boiler gas trains.
GF-xxxx	Gas Fired (an AERCO document numbering system)
GND	Ground
HDR	Header
Hex	Hexadecimal Number (0 – 9, A – F)
HP	Horse Power
HX	Heat Exchanger
Hz	Hertz (Cycles Per Second)
I.D.	Inside Diameter
IGN	Ignition
IGST Board	Ignition/Stepper Board, contained in the Controller
INTLK (INTL'K)	Interlock
I/O	Input/Output
I/O Box	Input/Output (I/O) Box currently used on Benchmark boilers
IP	Internet Protocol
ISO	International Organization for Standardization
Lbs.	Pounds (1 lb. = 0.45 kg)
LED	Light Emitting Diode
LN	Low Nitrogen Oxide
MA (mA)	Milliampere (1 thousand th of an ampere)
MAX (Max)	Maximum

AERCO Technical Terminology Meanings	
TERMINOLOGY	MEANING
MBH	1000 BTUs per Hour
MIN (Min)	Minimum
Modbus®	A serial, half-duplex data transmission protocol developed by AEG Modicon
NC (N.C.)	Normally Closed
NO (N.O.)	Normally Open
NO _x	Nitrogen Oxide
NPT	National Pipe Thread
O ₂	Oxygen
O.D.	Outside Diameter
OMM, O&M	Operation and Maintenance Manual
onAER	AERCO's on-line remote monitoring system
PCB	Printed Circuit Board
PMC Board	Primary Micro-Controller (PMC) board, contained in the C-More Controller
P/N	Part Number
POC	Proof of Closure
PPM	Parts per Million
PSI	Pounds per Square Inch (1 PSI = 6.89 kPa)
PTP	Point-to-Point (usually over RS232 networks)
P&T	Pressure and Temperature
ProtoNode	Hardware interface between BAS and a boiler or water heater
PVC	Poly Vinyl Chloride, a common synthetic plastic
PWM	Pulse Width Modulation
REF (Ref)	Reference
RES.	Resistive
RS232 (or EIA-232)	A standard for serial, full-duplex (FDX) transmission of data based on the RS232 Standard
RS485 (or EIA-485)	A standard for serial, half-duplex (HDX) transmission of data based on the RS485 Standard
RTN (Rtn)	Return
SETPT (Setpt)	Setpoint Temperature
SHLD (Shld)	Shield
SPDT	Single Pole Double Throw, a type of switch
SSOV	Safety Shut Off Valve
TEMP (Temp)	Temperature
Terminating Resistor	A resistor placed at each end of a daisy-chain or multi-drop network in order to prevent reflections that may cause invalid data in the communication
Tip-N-Tell	A device that indicates if a package was tipped during shipping
UL	A business that tests and validates products
VAC	Volts, Alternating Current
VDC	Volts, Direct Current
VFD	Variable Frequency Drive
VPS	Valve Proving System
W	Watt
W.C.	Water Column, a unit of pressure (1 W.C. = 249 Pa)
µA	Micro amp (1 million th of an ampere)

SECTION 1: SAFETY PRECAUTIONS

1.1 Warnings & Cautions

Installers and operating personnel **MUST**, at all times, observe all safety regulations. The following warnings and cautions are general and must be given the same attention as specific precautions included in these instructions. In addition to all the requirements included in this AERCO Instruction Manual, the installation of units **MUST** conform with local building codes, or, in the absence of local codes, ANSI Z223.1 (National Fuel Gas Code Publication No. NFPA-54) for gas-fired boilers and ANSI/NFPASB for LP gas-fired boilers. Where applicable, the equipment shall be installed in accordance with the current Installation Code for Gas Burning Appliances and Equipment, CSA B149.1, and applicable Provincial regulations for the class; which should be carefully followed in all cases. Authorities having jurisdiction should be consulted before installations are made.

See section 1.4 for important information regarding installation of units within the Commonwealth of Massachusetts.

IMPORTANT : This manual is an integral part of the product and must be maintained in legible condition. It must be given to the user by the installer and kept in a safe place for future reference.

WARNING!

- Do not use matches, candles, flames, or other sources of ignition to check for gas leaks.
- Fluids under pressure may cause injury to personnel or damage to equipment when released. Be sure to shut off all incoming and outgoing water shutoff valves. Carefully decrease all trapped pressures to zero before performing maintenance.
- Before attempting to perform any maintenance on the unit, shut off all gas and electrical inputs to the unit.
- The exhaust vent pipe of the unit may operate under a positive pressure and therefore must be completely sealed to prevent leakage of combustion products into living spaces.
- Electrical voltages up to 120 vac (bmk750 – 2000), 208 or 480 vac (bmk2500 – bmk3000), 480 vac (bmk4000 & 5000n), or 208, 480 or 575 vac (bmk5000 & 6000) and 24 volts ac may be used in this equipment. On international units, the voltage can be 220 v to 240 v single phase. Therefore, the cover on the unit's power panel (located behind the unit's front panel) must be installed at all times, except during maintenance and servicing.
- A single-pole (120 vac units) or three-pole (220 vac and higher units) switch must be installed on the electrical supply line of the unit. The switch must be installed in an easily accessible position to quickly and safely disconnect electrical service. Do not affix switch to unit sheet metal enclosures.

CAUTION!

- Many soaps used for gas pipe leak testing are corrosive to metals. The piping must be rinsed thoroughly with clean water after leak checks have been completed.
- **DO NOT** use this boiler if any part has been under water. Call a qualified service technician to inspect and replace any part that has been under water.

1.2 Emergency Shutdown

If overheating occurs or the gas supply fails to shut off, close the manual gas shutoff valve (Figure 1-1) located external to the unit. **NOTE:** The Installer must identify and indicate the location of the emergency shutdown manual gas valve to operating personnel.



Figure 1-1: Manual Gas Shutoff Valve

In addition, to ensure safety an emergency shutdown procedure that addresses the following points should be designed and implement at the site:

- For automatically operated unattended boilers located in a boiler room, provide a manually operated remote shutdown switch or circuit breaker located just inside or outside each boiler room door. Design the system so activation of the emergency shutdown switch or circuit breaker will immediately shut off the fuel supply to the unit(s).
- For automatically operated unattended boilers in a location other than a boiler room, provide a manually operated remote shutdown switch or circuit breaker marked for easy identification at a location readily accessible in the event of boiler mis-operation.
- Design the system so activation of the emergency shutdown switch or circuit breaker will immediately shut off the fuel.
- For boilers monitored and/or operated from a continuously occupied control room, provide an emergency shutdown switch in the control room that is hard-wired to immediately shut off the fuel upon activation.

1.3 Prolonged Shutdown

If there is an emergency, turn off the electrical power supply to the AERCO boiler and close the manual gas valve located upstream from the unit. The installer must identify the emergency shut-off device.

If the unit is being shut down for a long time, such as a year or more, complete the instructions in Section 8.11: *Shutting Boiler Down for Extended Period* in the *Benchmark Edge: OPERATION-SERVICE Manual* (OMM-0137, GF-211).

When returning a unit to service after a prolonged shutdown, it is recommended that the instructions in Section 4: *Initial Startup Procedures* and Section 5: *Safety Device Testing* of the *Benchmark -Edge: OPERATION-SERVICE Manual* (OMM-0137, GF-211) be performed to verify that all system-operating parameters are correct.

1.4 Important – For Massachusetts Installations

Requirements for Massachusetts Installations

Boiler Installations within the Commonwealth of Massachusetts must conform to the following requirements:

- Boiler must be installed by a plumber or a gas fitter who is licensed within the Commonwealth of Massachusetts.
- Prior to unit operation, the complete gas train and all connections must be leak tested using a non-corrosive soap.
- The vent termination must be located a minimum of 4 feet above grade level. If side-wall venting is used, the installation must conform to the following requirements **extracted from 248 CMR 5.08 (2)**:

(a) For all side wall horizontally vented gas fueled equipment installed in every dwelling, building or structure used in whole or in part for residential purposes, including those owned or operated by the Commonwealth and where the side wall exhaust vent termination is less than seven (7) feet above finished grade in the area of the venting, including but not limited to decks and porches, the following requirements shall be satisfied:

1. INSTALLATION OF CARBON MONOXIDE DETECTORS: At the time of installation of the side wall horizontal vented gas fueled equipment, the installing plumber or gasfitter shall observe that a hard-wired carbon monoxide detector with an alarm and battery back-up is installed on the floor level where the gas equipment is to be installed. In addition, the installing plumber or gasfitter shall observe that a battery operated or hard-wired carbon monoxide detector with an alarm is installed on each additional level of the dwelling, building or structure served by the side wall horizontal vented gas fueled equipment. It shall be the responsibility of the property owner to secure the services of qualified licensed professionals for the installation of hard-wired carbon monoxide detectors.

a. In the event that the side wall horizontally vented gas fueled equipment is installed in a crawl space or an attic, the hard-wired carbon monoxide detector with alarm and battery back-up may be installed on the next adjacent floor level.

b. In the event that the requirements of this subdivision cannot be met at the time of completion of installation, the owner shall have a period of thirty (30) days to comply with the above requirements; provided, however, that during said thirty (30) day period, a battery-operated carbon monoxide detector with an alarm shall be installed.

2. APPROVED CARBON MONOXIDE DETECTORS: Each carbon monoxide detector as required in accordance with the above provisions shall comply with NFPA 720 and be ANSI/UL 2034 listed and IAS certified.

3. SIGNAGE: A metal or plastic identification plate shall be permanently mounted to the exterior of the building at a minimum height of eight (8) feet above grade directly in line with the exhaust vent terminal for the horizontally vented gas fueled heating appliance or equipment. The sign shall read, in print size no less than one-half (1/2) inch in size, "**GAS VENT DIRECTLY BELOW. KEEP CLEAR OF ALL OBSTRUCTIONS**". (Continued)

4. INSPECTION: The state or local gas inspector of the side wall horizontally vented gas fueled equipment shall not approve the installation unless, upon inspection, the inspector observes carbon monoxide detectors and signage installed in accordance with the provisions of 248 CMR 5.08(2)(a)1 through 4.

Requirements for Massachusetts Installations

- (b) EXEMPTIONS: The following equipment is exempt from 248 CMR 5.08(2)(a)1 through 4:
 - 1. The equipment listed in Section 10 entitled "Equipment Not Required to Be Vented" in the most current edition of NFPA 54 as adopted by the Board.
 - 2. Product Approved side wall horizontally vented gas fueled equipment installed in a room or structure separate from the dwelling, building or structure used in whole or in part for residential purposes.

(c) MANUFACTURER REQUIREMENTS - GAS EQUIPMENT VENTING SYSTEM PROVIDED. When the manufacturer of Product Approved side wall horizontally vented gas equipment provides a venting system design or venting system components with the equipment, the instructions provided by the manufacturer for installation of the equipment and the venting system shall include:

- 1. Detailed instructions for the installation of the venting system design or the venting system components; and
- 2. A complete parts list for the venting system design or venting system.

(d) MANUFACTURER REQUIREMENTS - GAS EQUIPMENT VENTING SYSTEM NOT PROVIDED. When the manufacturer of a Product Approved side wall horizontally vented gas fueled equipment does not provide the parts for venting the flue gases, but identifies "special venting systems", the following requirements shall be satisfied by the manufacturer:

- 1. The referenced "special venting system" instructions shall be included with the appliance or equipment installation instructions; and
- 2. The "special venting systems" shall be Product Approved by the Board, and the instructions for that system shall include a parts list and detailed installation instructions.

(e) A copy of all installation instructions for all Product Approved side wall horizontally vented gas fueled equipment, all venting instructions, all parts lists for venting instructions, and/or all venting design instructions shall remain with the appliance or equipment at the completion of the installation.

.....[End of Extracted Information From 248 CMR 5.08 (2)].....

SECTION 2: INSTALLATION

2.1 Introduction

This section provides the descriptions and procedures necessary to unpack, inspect and install AERCO Benchmark Boilers.

2.2 Receiving The Unit

Each Benchmark Boiler System is shipped as a single crated unit. The shipping weight for these BMK models is approximately as follows:

- **BMK750:** 1,100 lbs. (499 kg)
- **BMK1000:** 1,200 lbs. (544 kg)
- **BMK1500/2000:** 1,800 lbs. (817 kg).
- **BMK2500/3000:** 2,200 lbs. (1000 kg)
- **BMK4000/5000N:** 2,500 lbs. (1134 kg)
- **BMK5000/6000:** 3,800 lbs. (1724 kg)

The unit must be moved with the proper rigging equipment for safety and to avoid equipment damage. The unit should be completely inspected for evidence of shipping damage and shipment completeness at the time of receipt from the carrier and before the bill of lading is signed.

CAUTION!

While packaged in the shipping container, the unit must be moved by pallet jack or forklift from the front only.

NOTE: AERCO is not responsible for lost or damaged freight. Each unit has A Tip-N-Tell indicator on the outside of the crate, which indicates if the unit has been turned on its side during shipment. If the Tip-N-Tell indicator is tripped, do not sign for the shipment. Note the information on the carrier's paperwork and request a freight claim and inspection by a claims adjuster before proceeding. Any other visual damage to the packaging materials should also be made clear to the delivering carrier.

2.3 Unpacking

Carefully unpack the unit taking care not to damage the unit enclosure when cutting away packaging materials

After unpacking, make a close inspection of the unit to ensure that there is no evidence of damage not indicated by the Tip-N-Tell indicator. The freight carrier should be notified immediately if any damage is detected.

The following accessories come standard with each unit and are either packed separately within the unit's shipping container or are factory installed on the unit:

- Pressure/Temperature Gauge
- ASME Pressure Relief Valve
- Condensate Drain Trap (P/N 24441)
- A 1", 1-1/2" or 2" Natural Gas Supply Shutoff Valve, and a Propane Shutoff Valve on Propane and Dual Fuel units

When optional accessories are ordered, they may be packed within the unit's shipping container, factory installed on the unit, or packed and shipped in a separate container. Any standard or optional accessories shipped loose should be identified and stored in a safe place until ready for installation or use.

SECTION 2 – INSTALLATION

2.4 Site Preparation

Ensure that the site selected for installation of the Benchmark Boiler includes:

- Access to a natural and/or propane gas supply that conforms to the pressures specified in the *Benchmark Gas Supply Design Guide* (TAG-0047).
- AC input power as specified in *Benchmark Electrical Power Design Guide* (TAG-0048).
- To ensure proper condensate drainage, the unit must be installed on a level concrete “housekeeping” pad. See Section 2.4.3 for pad requirements.

2.4.1 Installation Clearances

All Benchmark models are the same height, but vary in depth by model. The unit must be installed with the prescribed clearances for service as shown in Figure 2-1a through 2-1e. The minimum clearance dimensions, required by AERCO, are listed below for all models. However, if Local Building Codes require additional clearances, these codes shall supersede AERCO’s requirements.

The **minimum acceptable clearances** required are as follows:

BMK750 – 5000N

- Front: 24 inches (61 cm)
- Sides: 24 inches (61 cm)
- Rear: 24 inches (61 cm)
- Top: 18 inches (45.7 cm)

BMK5000-6000

- Front: 36 inches (91 cm)
- Sides: 24 inches (61 cm)
- Rear: 24 inches (61 cm)
- Top: 18 inches (45.7 cm)

All gas piping, water piping and electrical conduit or cable must be arranged so that they do not interfere with the removal of any panels or inhibit service or maintenance of the unit.

In multiple unit installations, it is important to plan the position of each unit in advance. Sufficient space for piping connections and future service/maintenance requirements must also be taken into consideration. All piping must include ample provisions for expansion.

NOTE: Benchmark units may be installed with zero side clearances in pairs only. The perimeter clearances still apply. See drawings in *Appendix A*.

If installing a Combination Control System (CCS) using an ACS panel (ACS is not needed for combination mode, but can still be used if installing with a legacy BMK unit, or if you already have a panel want to continue to use it), it is important to identify the **Combination Mode** Boilers in advance and place them in the proper physical location. For more information refer to Section 6.6: *Combination Control System* of the *Benchmark -Edge: Operation-Service-Maintenance Manual* (OMM-0137, GF-211).

SECTION 2 – INSTALLATION

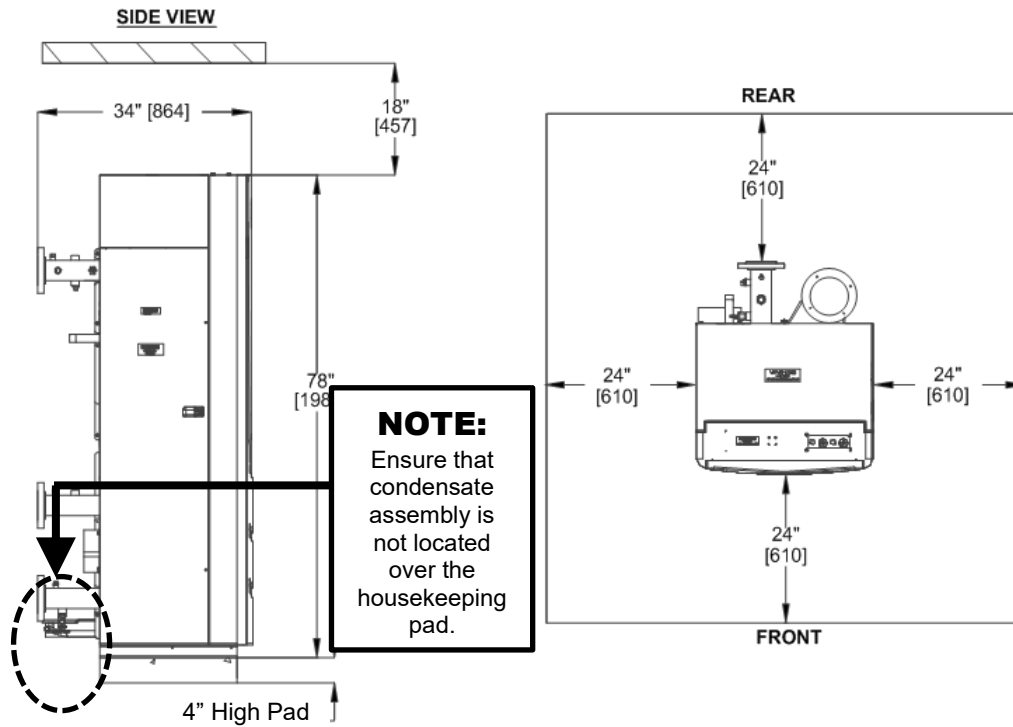

Figure 2-1a: BMK750/1000 Clearances

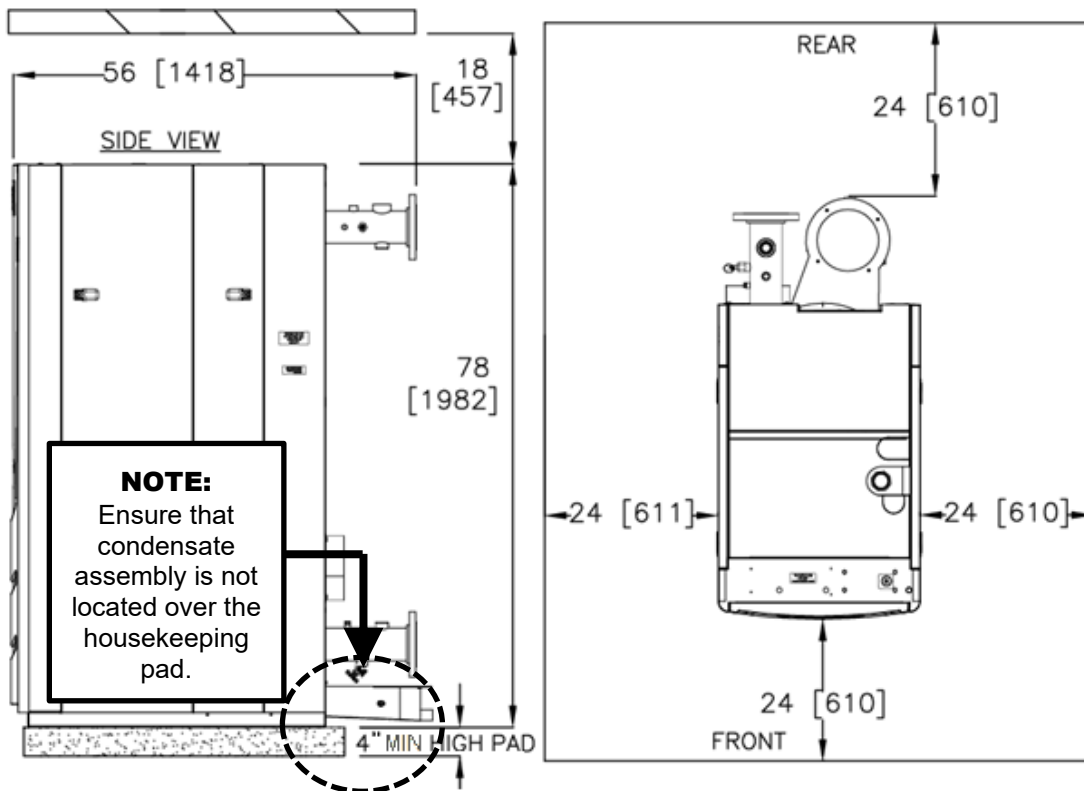

Figure 2-1b: BMK1500/2000 Clearances

SECTION 2 – INSTALLATION

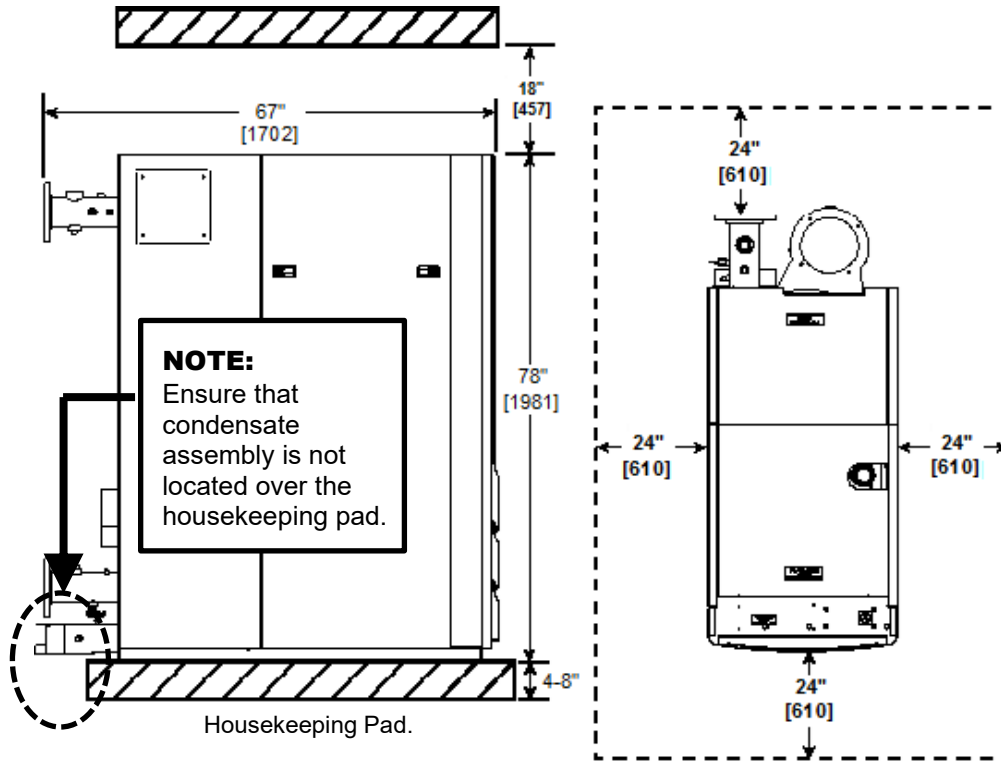

Figure 2-1c: BMK2500/3000 Clearances

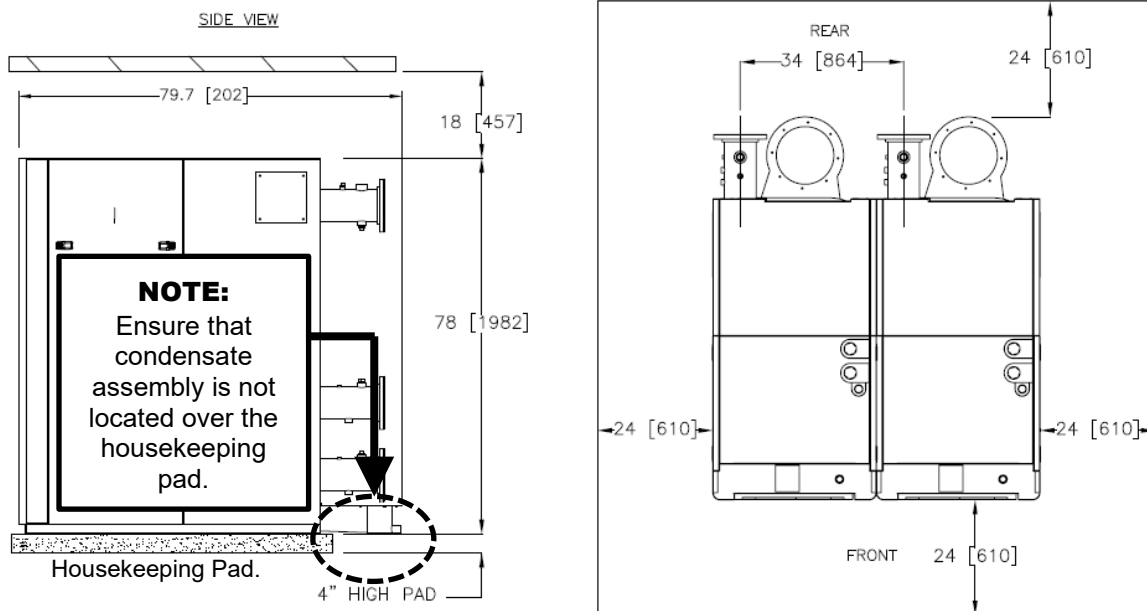

Figure 2-1d: BMK4000-5000N Clearances

SECTION 2 – INSTALLATION

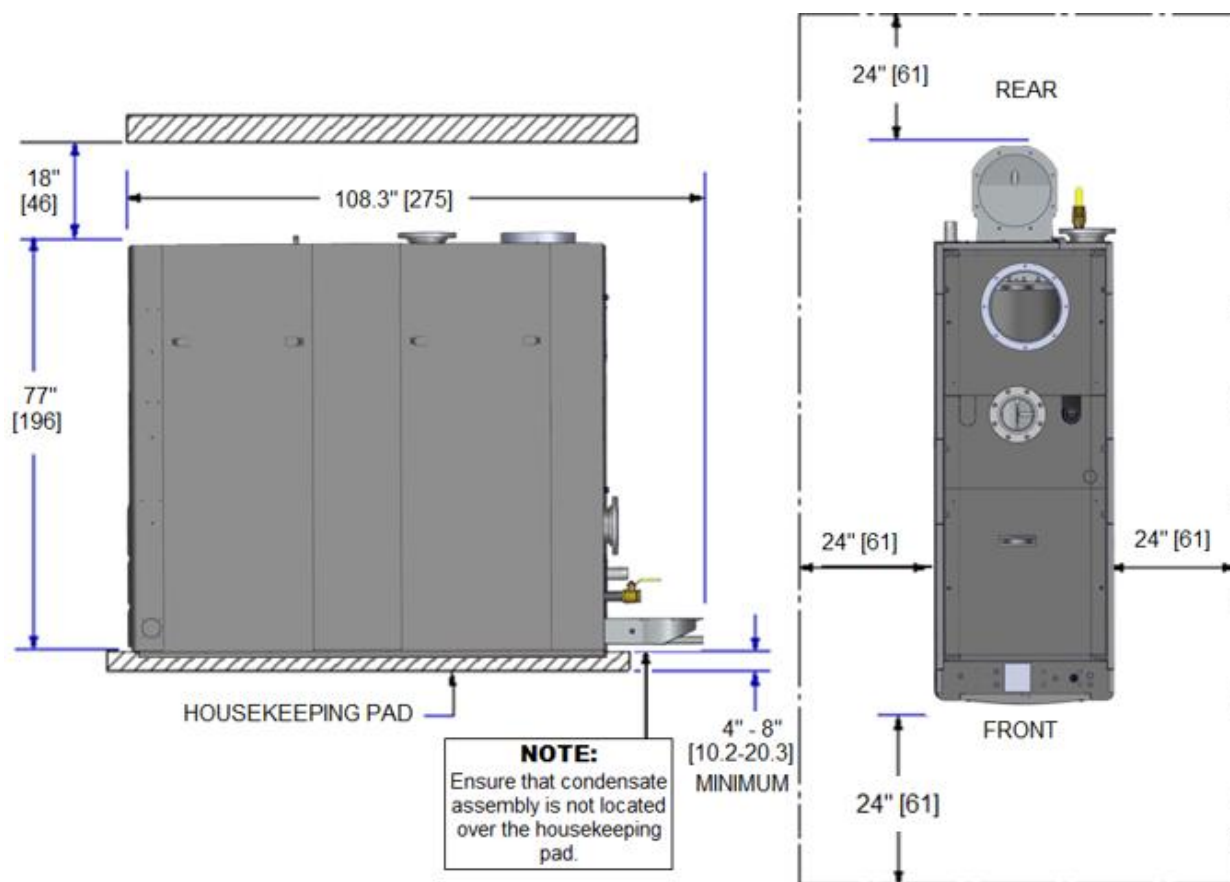

Figure 2-1e: Benchmark Model 5000 & 6000 Clearances

WARNING!

Keep unit area clear and free from all combustible materials and flammable vapors or liquids.

FOR MASSACHUSETTS ONLY:

For Massachusetts installations, the unit must be installed by a plumber or gas-fitter licensed within the Commonwealth of Massachusetts. In addition, the installation must comply with all requirements specified in Section 1.4, above.

2.4.2 Setting the Unit

If anchoring the unit, refer to Figure 2-2a through 2-2e for anchor locations.

- All holes are flush with the bottom surface of the frame.
- All dimensions shown are in inches [millimeters]

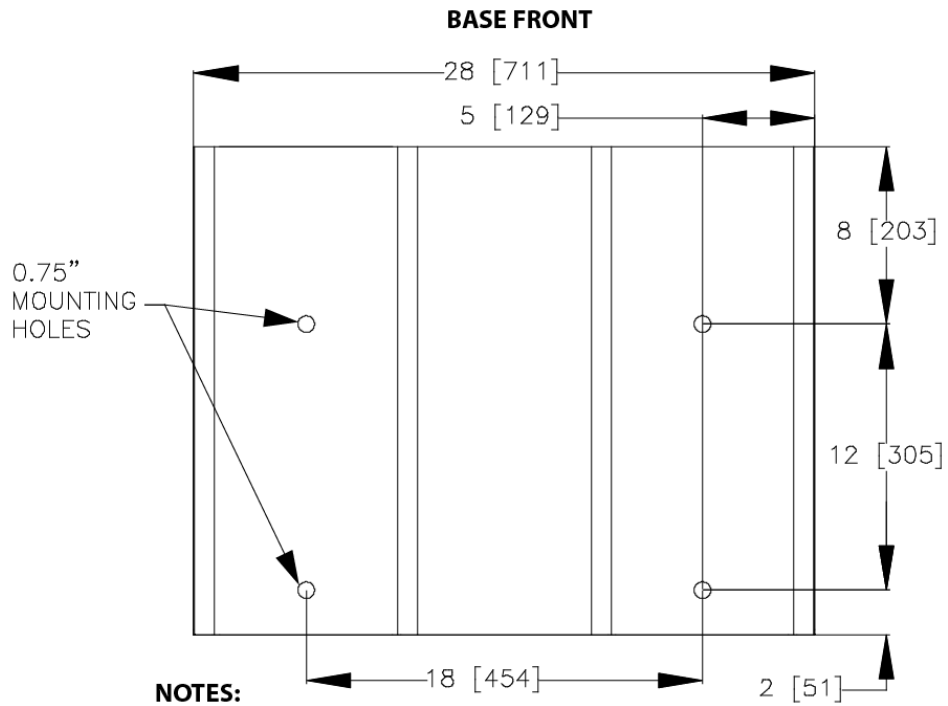

Figure 2-2a: BMK750/1000 Anchor Bolt Locations

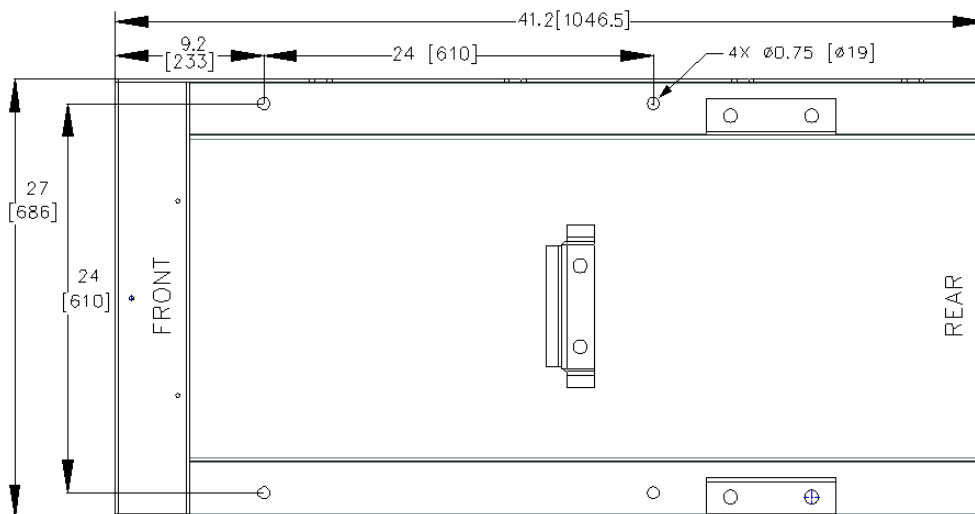

Figure 2-2b: BMK1500/2000 Anchor Bolt Locations

SECTION 2 – INSTALLATION

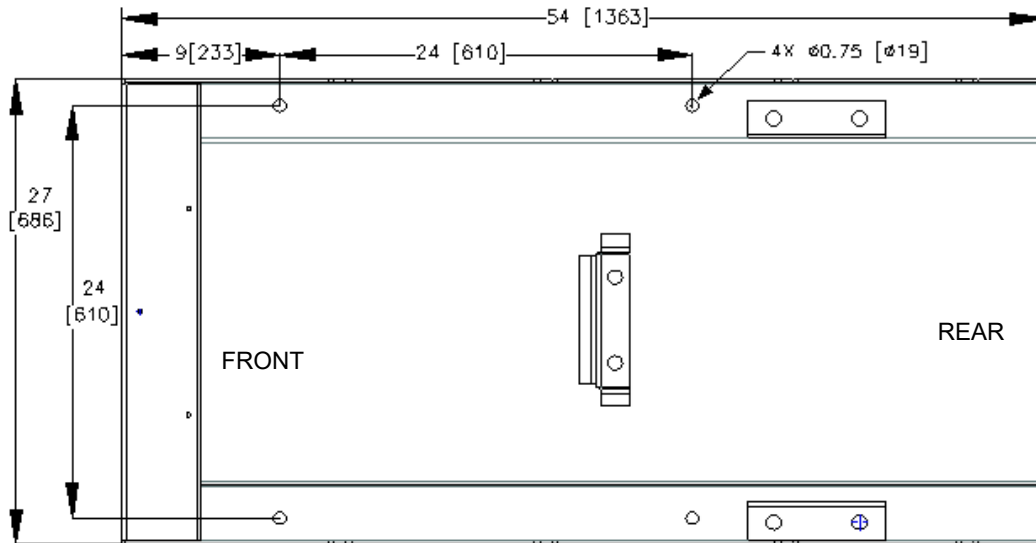

Figure 2-2c: BMK2500/3000 Anchor Bolt Locations

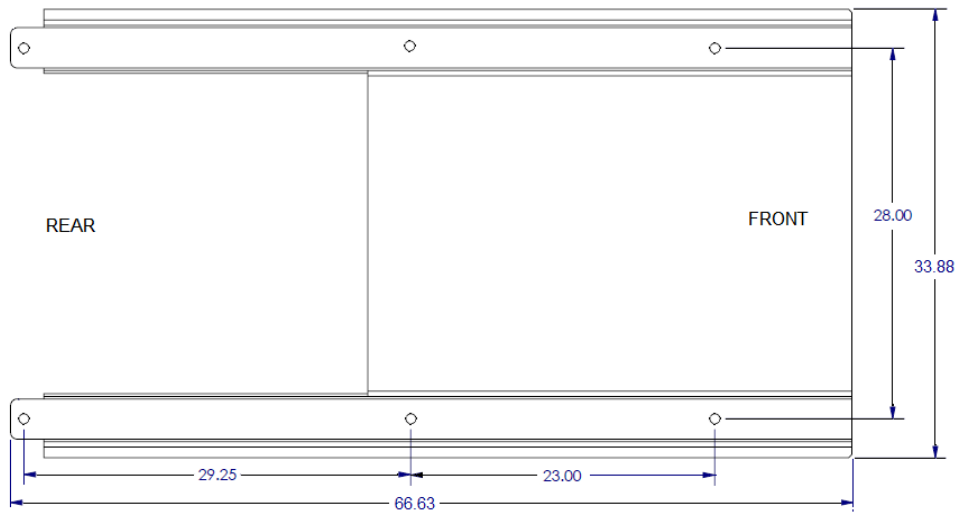

Figure 2-2d. BMK4000-5000N Anchor Bolt Locations

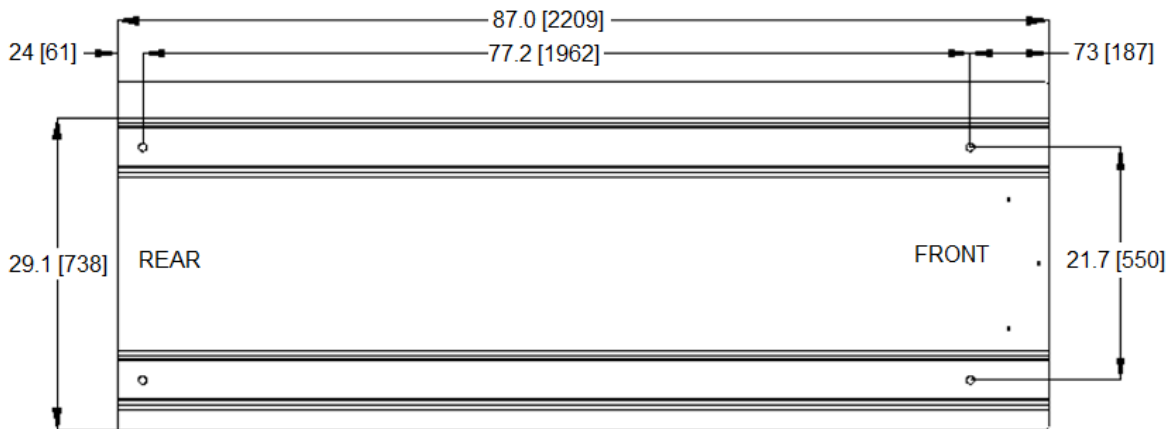

Figure 2-2e. BMK5000/6000 Anchor Bolt Locations

SECTION 2 – INSTALLATION

2.4.3 Housekeeping Pad Requirements

To ensure proper condensate drainage, the unit must be installed on a level concrete “housekeeping” pad. The unit must be positioned on the pad such that the condensate assembly is not located over the pad, as shown below.

The minimum thickness of the concrete “housekeeping” pad depends on two factors:

- Which Benchmark model you’re installing
- Whether the unit will connect to a Condensate Neutralizer tank.

The minimum pad thickness for installations without a Condensate Neutralizer tank are:

- Benchmark 750 & 1000: **4 to 6 inches** (10.2 to 15.2 cm)
- Benchmark 1500 to 6000: **4 to 8 inches** (10.2 to 20.3 cm)

If you are using the AERCO Condensate Neutralizer Tank (P/N **89030**), you must ensure enough height for the condensate to drain into the condensate trap, then into the neutralizer tank, and then to the drain. This may require that a pit be dug for the Neutralizer Tank. For more information on the Condensate Neutralizer Tank, see Technical Instructions TID-0074.

The following table specifies the minimum pit depth for the AERCO Condensate Neutralizer Tank (P/N **89030**) if the boiler is installed on a **4" pad**, and the pad height if the Neutralizer Tank must be installed on the floor; note, in all cases a **6" pad** eliminates the need to a pit.

BMK Model	Minimum Pit Depth	Pad Height Without Pit
750/1000	Pit not required	4"
1500/2000	1-1/4"	5-1/4"
2500/3000	1"	5"
4000/5000N	1-3/4"	5-3/4"
5000/6000	Pit not required	6"

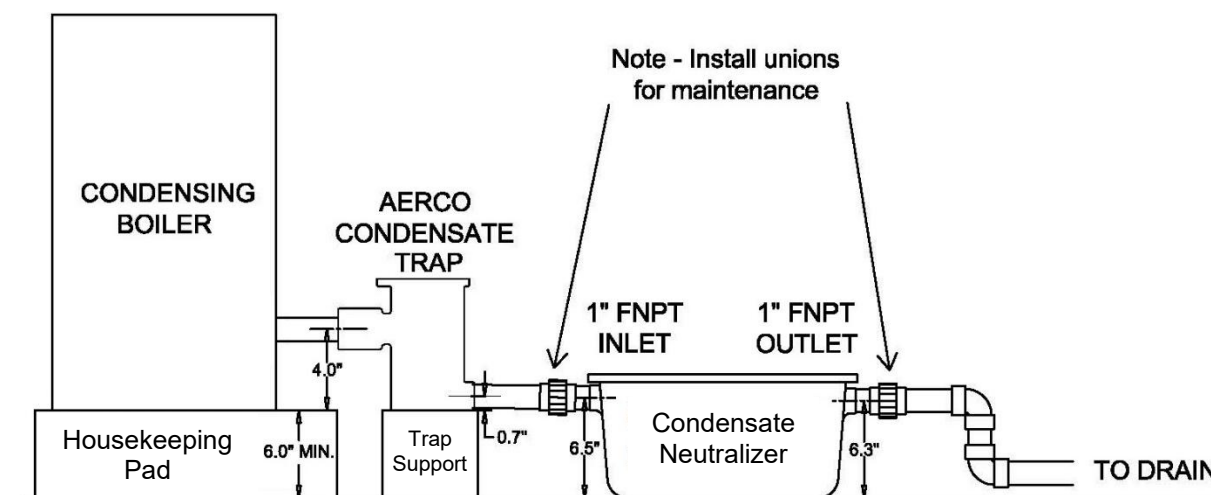

Figure 2-3: Condensate Neutralizer Tank Installation

2.5 Lifting Provisions

WARNING: Do **NOT** manipulate the boiler using the gas train or blower when moving.

2.5.1 BMK750 – 1000 Lifting Provisions

Unpack and inspect the unit, then remove the four (4) lag screws securing the boiler to the shipping pallet. The boiler can be lifted and moved by inserting forklift tines in the front slots provided in the base of the unit, or it can be lifted by attaching a lifting bar to the unit's heat exchanger. A lifting bar (P/N **59174**), with attaching hardware, is supplied with each unit. When shipped, this bar is attached to the rear of the unit as shown in Figure 2-4a (View A). One (1) lifting tab is provided at the top of the unit's heat exchanger as shown. This tab is used to attach the lifting bar to the unit, as described below.

WARNING: When using the lifting tab, ensure no load is placed on the gas train or blower.

Attaching the Lifting Bar: BMK750/1000:

1. Remove the lifting bar from its shipping location at the rear of the unit (Figure 2-4a, View A). Retain the two (2) hex head cap screws, hex nuts and flat washers.
2. Remove the top shroud from the boiler and locate the lifting tab at the top-rear of the heat exchanger.
3. Attach the lifting bar to the heat exchanger lifting tab using the hardware removed in step 1 (Figure 2-4a, View B). The upper end of the lifting bar containing the oval cutout should be positioned over the top of the heat exchanger as shown.
4. Using proper rigging equipment capable of lifting **1200 lbs. (544 kg)**, lift the boiler and position it on the housekeeping pad.
5. After the boiler is properly set on the pad, detach the lifting bar and replace the shroud on the top of the unit, but retain the lifting bar for possible reuse at the installation site.

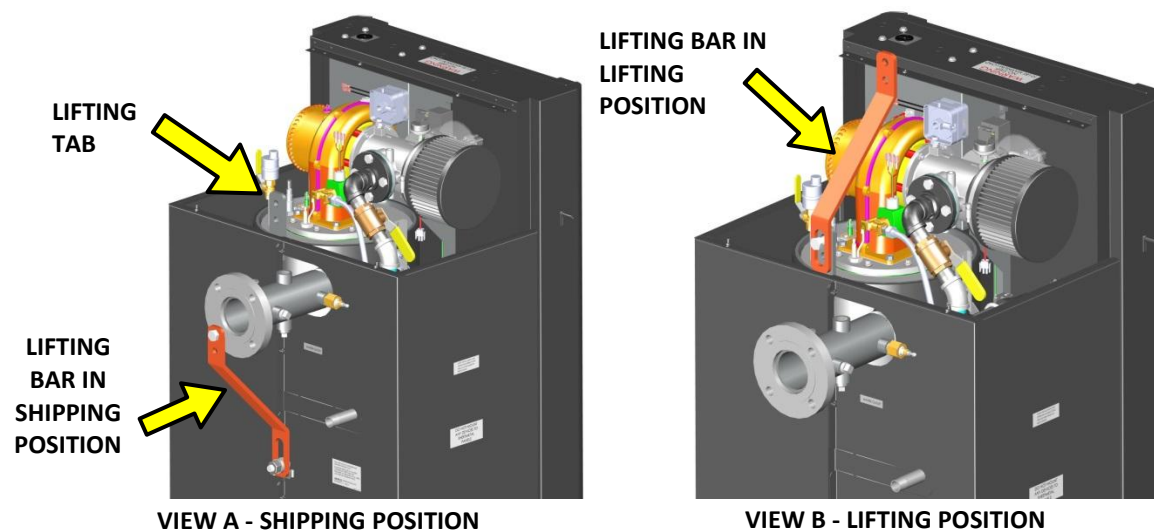

Figure 2-4a: BMK750/1000 Boiler Lifting Provisions

SECTION 2 – INSTALLATION

2.5.2 BMK1500 – 5000N Lifting Provisions

Three lifting lugs are provided at the top of the primary heat exchanger as shown in Figure 2-4b. Remove the front top panel from the unit to provide access to the lifting lugs. Remove the four (4) lag screws securing the unit to the shipping skid. Lift the unit off the shipping skid and position it on the 4 inch to 8-inch (10.2 cm to 20.3 cm) housekeeping concrete pad (required) in the desired location.

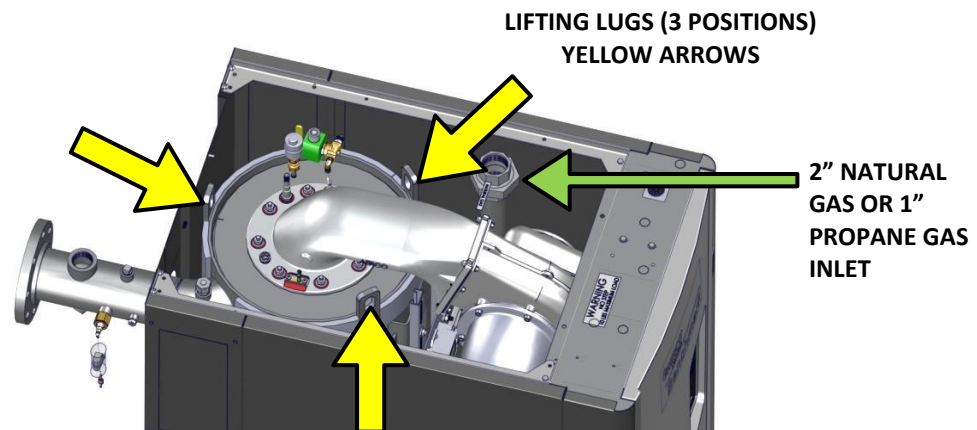

Figure 2-4b: Boiler Lifting Provisions – BMK1500/2000 Shown

2.5.3 BMK5000 & 6000 Lifting Provisions

Two (2) lifting lugs are provided at the top of the primary heat exchanger (see Figure 2-4c). The location of the lifting tabs is marked on the shrink-wrap covering the unit for shipping.

Remove the four (4) lag screws securing the unit to the shipping skid, and, if still in place, remove the front Top Panel. Lift the unit off the shipping skid using a spreader bar and position it on the (required) concrete Housekeeping Pad in the desired location.

WARNING!

When lifting or moving the boiler, do not attempt to manipulate the unit using the gas train or blower. A spreader bar is required for all vertical lifts. Failure to use a spreader bar can put excessive force on the unit and can cause boiler failure.

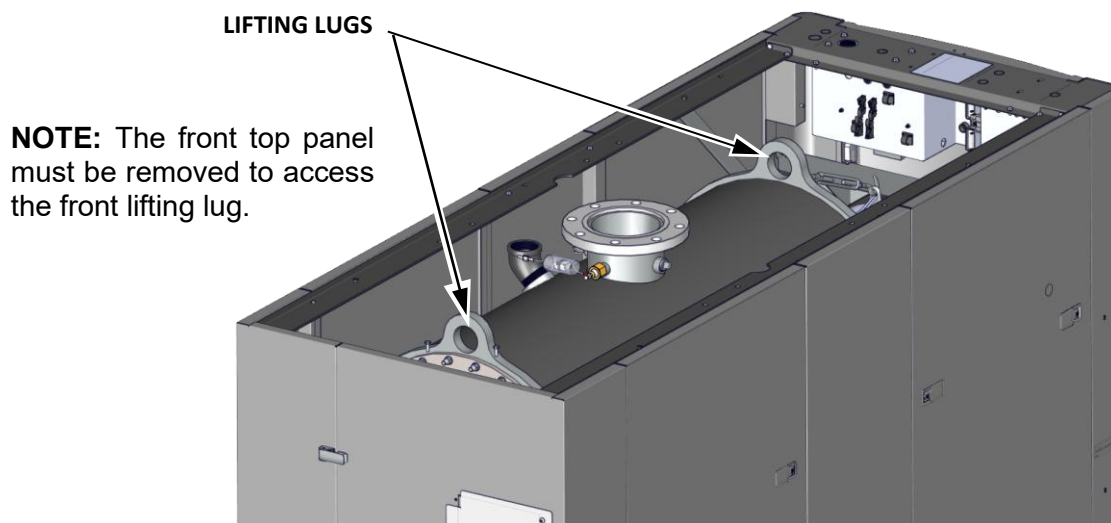

Figure 2-4c: Lifting Lug Locations – BMK5000 & 6000

SECTION 2 – INSTALLATION

2.6 Supply And Return Piping

When connecting the hot water outlet and cold-water inlet to building piping, first make sure the mating surfaces are thoroughly clean. Gaskets of appropriate size for the pipe flange must be provided in the field.

Operating the unit above the maximum flow requirements of the boiler will void warranty.

NOTE: If the boiler is equipped with dual returns, but only one connection will be used, be sure to connect your return piping to the primary/lower connection.

2.6.1 BMK750 – 1000 Supply and Return Piping

Benchmark 750 and 1000 Boiler utilizes 3" (7.62cm) 150# flanges for the water system supply and return piping connections. The physical location of the supply and return piping connections are on the rear of the unit as shown in Figure 2-5a.

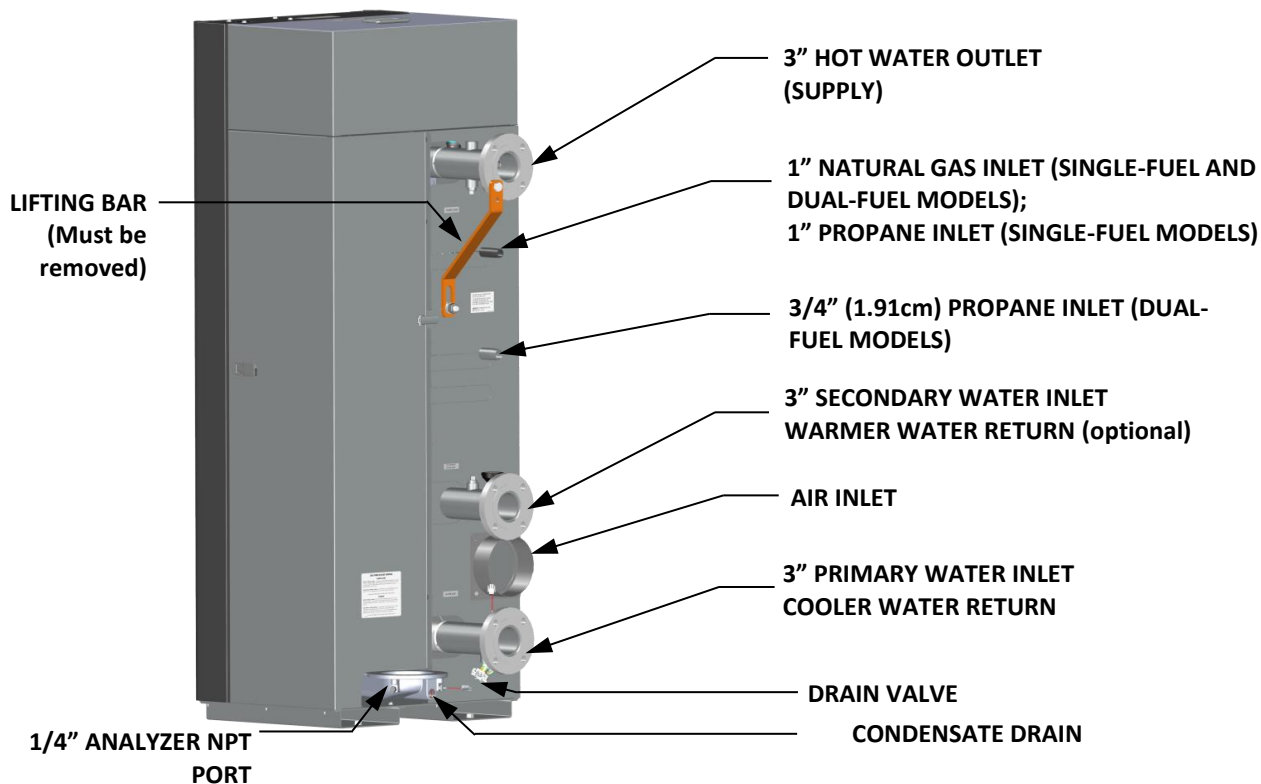

Figure 2-5a: BMK750/1000 Supply and Return Locations

2.6.2 BMK1500 – 5000N Supply and Return Piping

Benchmark 1500 – 3000 units have the following inlets and outlets:

- 4" (10.2 cm) 150# flange water INLET (supply) and hot water OUTLET (return) piping.
- One of the following gas inlet pipes:
 - 2" (5.08 cm) Natural Gas inlet pipe.
 - 1" (2.54 cm) Propane inlet pipe (BMK 1500-2000).
 - 2" (5.08 cm) Propane inlet pipe (BMK 2500-3000).
- 8" (20.3 cm) Air Inlet adapter.

SECTION 2 – INSTALLATION

Benchmark 4000 and 5000N units have:

- 6” (15.2 CM) 150# flange water INLET (supply) and hot water OUTLET (return) piping.
- One of the following gas inlet pipes:
 - 3” (7.62 cm) Natural Gas inlet pipe.
 - 1.5” (3.81 cm) Propane inlet pipe
- 10” (25.4 cm) Air Inlet adapter.

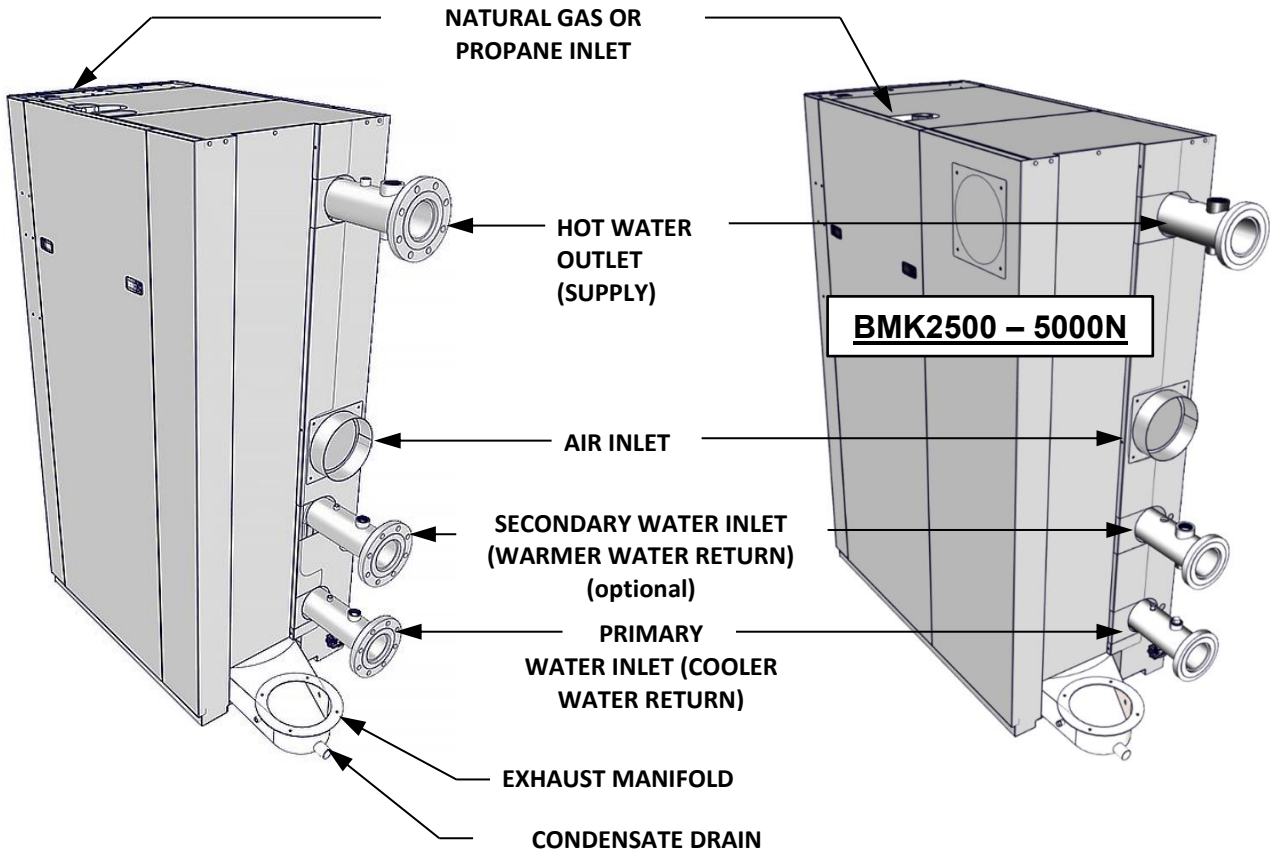

Figure 2-5b: BMK1500 – 5000N Supply and Return Locations

SECTION 2 – INSTALLATION

2.6.3 BMK5000 – 6000 Supply and Return Piping

Benchmark 5000 and 6000 boilers utilize 6" (15.24 cm) flanged fittings for the water system supply and return piping connections. The physical location of the supply and return piping connections are shown in Figure 2-5c.

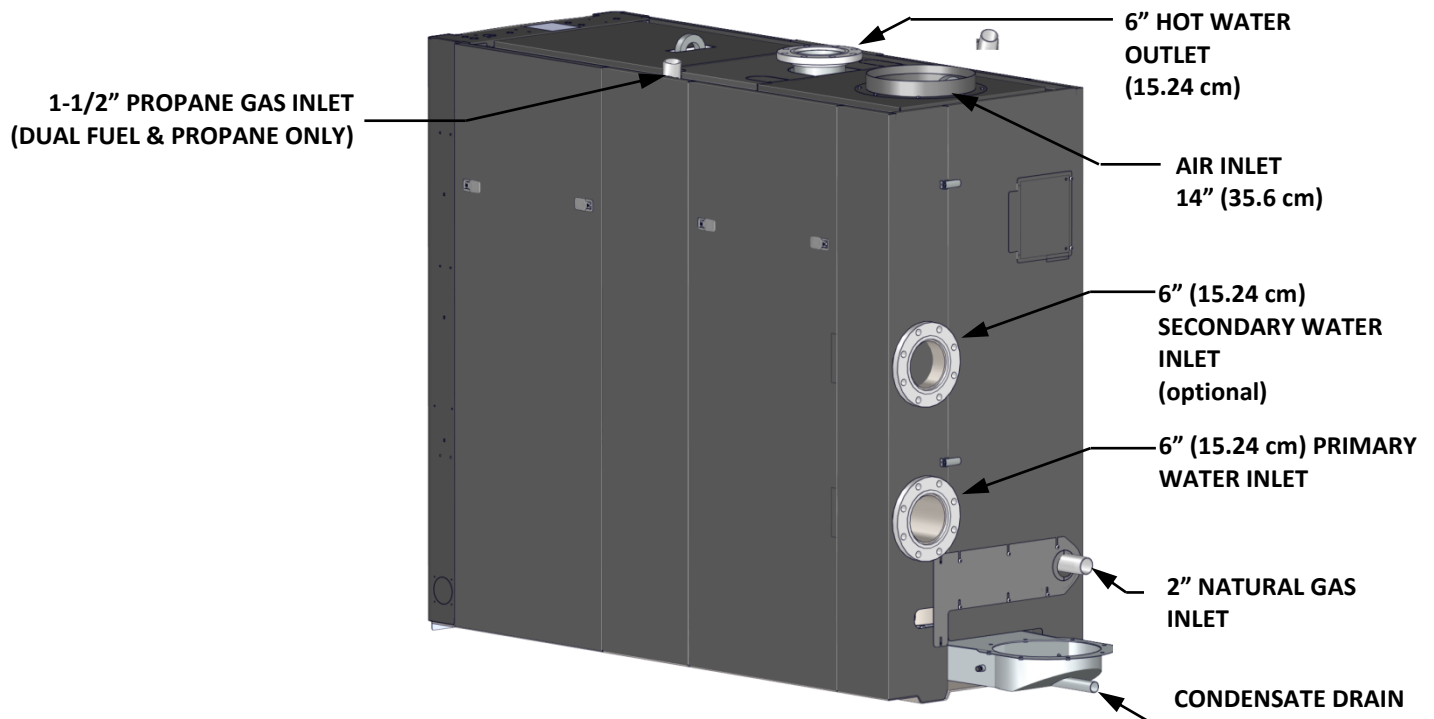

Figure 2-5c: BMK5000 & 6000 Supply and Return Locations (DF Model Shown)

2.6.4 Dual Inlet Return Piping

Optional dual inlet connections allow Benchmark units to be configured with a separate cooler return temperature zone, rather than blending high and low return temperature zones. When configured with a lower return temperature zone or AERCO SmartPlate EV, thermal efficiency can improve by up to 6% (based on an 80 °F (26.7 °C) minimum return water temperature at full fire). Lower return temperatures are possible, which would yield even greater efficiency. The maximum temperature differential across the boiler heat exchanger is 100 °F (37.8 °C).

IMPORTANT!

The secondary (optional) inlet **MUST** be blanked off if not in use.

To use the secondary inlet, pipe the **warmer** return water to the **secondary** (upper) inlet and the **cooler** return water to the **primary** (lower) inlet. If the flow through both the primary and the secondary return is constant, then the combined minimum flows must equal the specified minimum flow of the boiler. If the flow through either of the inlet returns is intermittent, then the minimum flow through one of the return connections must always equal the specified minimum flow of the boiler. The combined flows of the primary and secondary return cannot exceed the maximum flow specified for each Benchmark model. Contact your AERCO representative for additional information.

SECTION 2 – INSTALLATION

2.7 Water Quality – Initial System Fill

Water quality guidelines should be strictly adhered to prevent corrosion of the heat exchanger and other system components. While the Benchmark 439 Stainless Steel Heat Exchanger has been in the market for many years and has proven to be robust and resist damage due to water quality, it is important to understand the chemical composition of incoming water to the boiler.

Heat exchanger failure due to water quality are not covered under warranty.

To prevent potential corrosion, fouling, and harmful effects on the boiler, the water quality guidelines listed below should be adhered to:

- Chloride limits are set to 250 ppm to prevent corrosion of the heat exchanger. In the table below, your Chloride test result dictates which row you must be in.
- Sulfates are limited to lower ppm limits as the tested chloride levels increase and are acceptable at any ppm when chlorides are less than 100 ppm
- Allowable hardness depends on the concentration of sulfates and chlorides and should not exceed 50 ppm

EXAMPLE: If the chloride is between 175 and 250, sulfate must be 25 ppm or below, and hardness must be 10 ppm or below for the boiler to operate smoothly with minimal risk.

MAINTENANCE: Water quality should be analyzed 3 months after startup. If found in compliance with guidelines described below, water quality should be analyzed as part of annual maintenance.

NOTE: Systems with leaks can cause significant amounts of make-up water, creating a loop that is no longer considered “closed” and allowing contaminants in with the replenished make-up water. AERCO recommends the installation of a positive displacement flow meter on the make-up water line to sense any freshwater make-up introduction. Water quality should be verified in the event of freshwater being introduced into the boiler loop and treated as necessary to meet guidelines below. Contact your local AERCO Sales Representative or AERCO Technical Services if you have any questions.

Chloride (ppm)	Sulfate (ppm)	Hardness (ppm)	pH	Conductivity (umho/cm)
< 250	≤ 25	≤ 10	7-10.5	≤ 3500
< 175	≤ 50	≤ 25	7-10.5	≤ 3500
< 100	No Limit	≤ 50	7-10.5	≤ 3500

Definitions:

- Chlorides - Causes stainless steel to corrode
- Sulfates – Accelerates corrosion of stainless steel in the presence of chlorides
- Hardness - Keeping hardness values low will help to prevent scale buildup
- pH – The first step towards boiler treatment, maintain between 7-10.5
- Conductivity - The increase of total solids promotes deposition of scales

SECTION 2 – INSTALLATION

2.8 Pressure Relief Valve Installation

An ASME rated Pressure Relief Valve is supplied with each Benchmark Boiler (BMK5000 and 6000 boilers are supplied with one or more valves, depending on the pressure required). The pressure rating for the relief valve must be specified on the sales order. Available pressure ratings range from **30 to 160 psi (207 to 1103 kPa)**. The relief valve is installed on the hot water outlet of the boiler as shown in Figure 2-6a – 2-6c. A suitable pipe joint compound should be used on the threaded connections. Any excess should be wiped off to avoid getting any joint compound into the valve body. The relief valve must be piped to **within 12 inches (30.5 cm)** of the floor to prevent injury in the event of a discharge. No valves, restrictions, or other blockages are allowed in the full port discharge line. In multiple unit installations the discharge lines must **NOT** be manifolded together. Each must be individually run to a suitable discharge location.

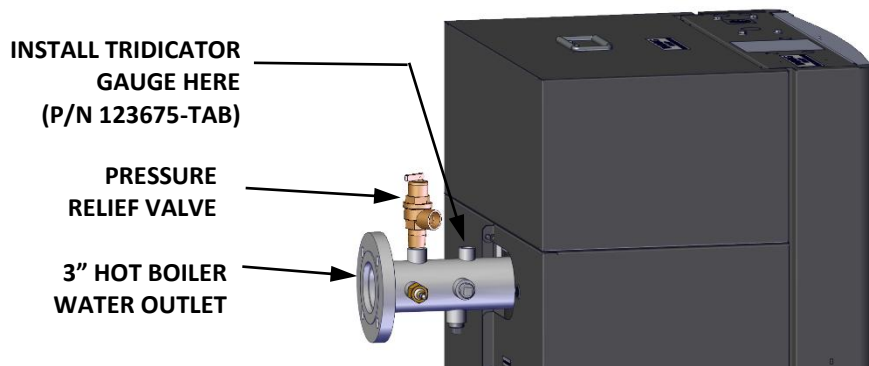

Figure 2-6a: BMK750/1000 P&T Relief Valve Location

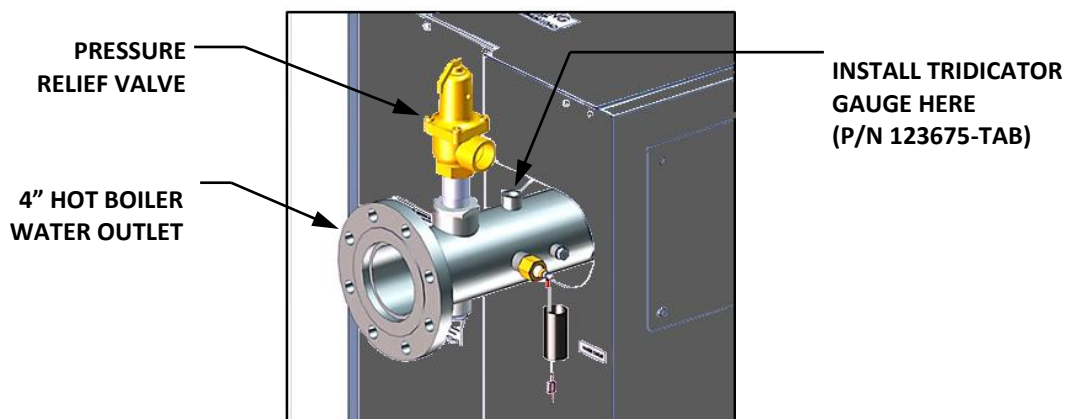

Figure 2-6b: BMK1500 – 5000N P&T Relief Valve Location

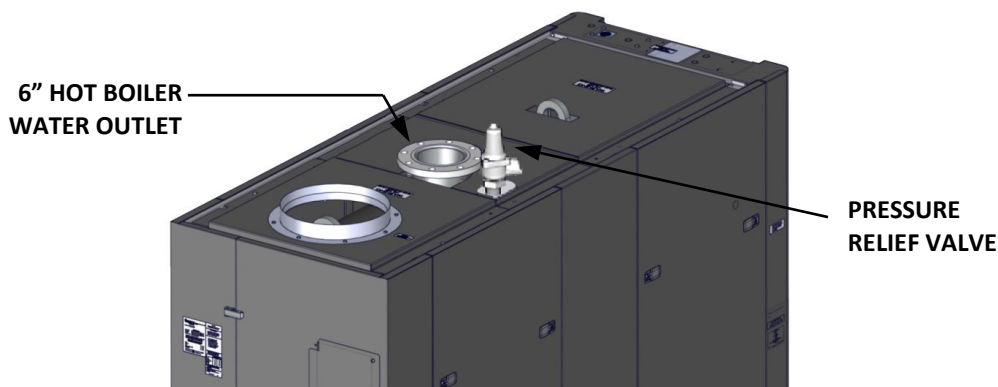

Figure 2-6c. BMK5000 – 6000 P&T Relief Valve Location

SECTION 2 – INSTALLATION

Benchmark Nozzle Sizes	
Benchmark Model	Connection Size (NPT)
750-1000	¾"
1500-3000	1 ½"
4000-6000	2"

2.9 Pressure/Temperature Gauge Installation

A Pressure/Temperature Gauge is included in the loose parts kit for installation in the boiler outlet piping. It must be installed so that the sensing bulb is inserted into the hot water outlet flow from the boiler, as shown below.

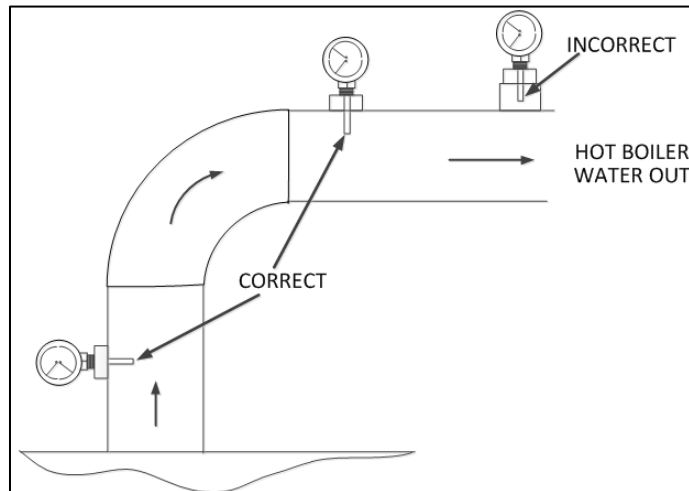

Figure 2-7: Pressure/Temperature Gauge Installation Location

2.10 Condensate Drain and Piping

The Benchmark Boiler is designed to condense water vapor from the flue products. Therefore, the installation must have provisions for suitable condensate drainage or collection. See below for information on the condensate drain and piping for the various models.

The condensate drain port located on the exhaust manifold (see Figure 2-7a and 2-7b, below) must be connected to the condensate trap (P/N 24762 or **24441**), which is packed separately within the unit's shipping container. Its inlet and outlet connections contain tapped ¾" NPT ports.

A sample condensate trap installation is shown in Figure 2-7a and 2-7b. However, the actual installation details for the trap will vary depending on the available clearances, housekeeping pad height/dimensions and other prevailing conditions at the site.

NOTE: The following guidelines **must** be observed to ensure proper condensate drainage:

- Condensate trap inlet must be level with or lower than the exhaust manifold drain port.
- The base of the condensate trap must be supported to ensure that it is level (horizontal).
- The trap must be removable for routine maintenance. AERCO recommends that a union be utilized between the exhaust manifold condensate drain port and the trap inlet port.
- If the condensate trap does not connect directly to the exhaust manifold condensate drain port, the pipe between the drain and the trap **must** be **stainless steel** or **aluminum**.
- The concrete housekeeping pad must not extend under the condensate assembly.

SECTION 2 – INSTALLATION

Condensate Drain Installation

1. Connect the condensate trap inlet to the exhaust manifold drain connection using the appropriate piping components (nipples, reducers, elbows, etc.).
2. At the condensate trap outlet, install a 3/4" NPT nipple.
3. Connect 1" (2.54 cm) I.D. of polypropylene hose to the trap outlet and secure with a clamp.
4. Route the hose on the trap outlet to a condensate neutralizer tank or nearby floor drain.

Optional Pipe Extensions for Extended Housekeeping Pads

AERCO offers an optional 24" or 36" extension if the condensate trap cannot be directly connected to the exhaust manifold. The 24" extension kit is 24800-24 and the 36" kit is 24800-36.



Item	Part #	Description	QTY
10	93283	Adapter Assembly	1
11	24800-24	Pipe Extension (24")	1
11	24800-36	Pipe Extension (36")	1

WARNING!

Use PVC, stainless steel, aluminum, or polypropylene for condensate drain piping. Do **NOT** use carbon or copper components.

If a floor drain is not available, a condensate pump can be used to remove the condensate to an appropriate drain. The maximum condensate flow rate is:

Model	Maximum Condensate Flow Per Boiler		
BMK750	6 gallons (23 L) per hour	BMK3000	20 gallons (76 L) per hour
BMK1000	8 gallons (30 L) per hour	BMK4000	30 gallons (114 L) per hour
BMK1500	9 gallons (34 L) per hour	BMK5000N	33 gallons (125 L) per hour
BMK2000	10 gallons (38 L) per hour	BMK5000	34 gallons (128 L) per hour
BMK2500	17 gallons (64 L) per hour	BMK6000	40 gallons (151 L) per hour

SECTION 2 – INSTALLATION

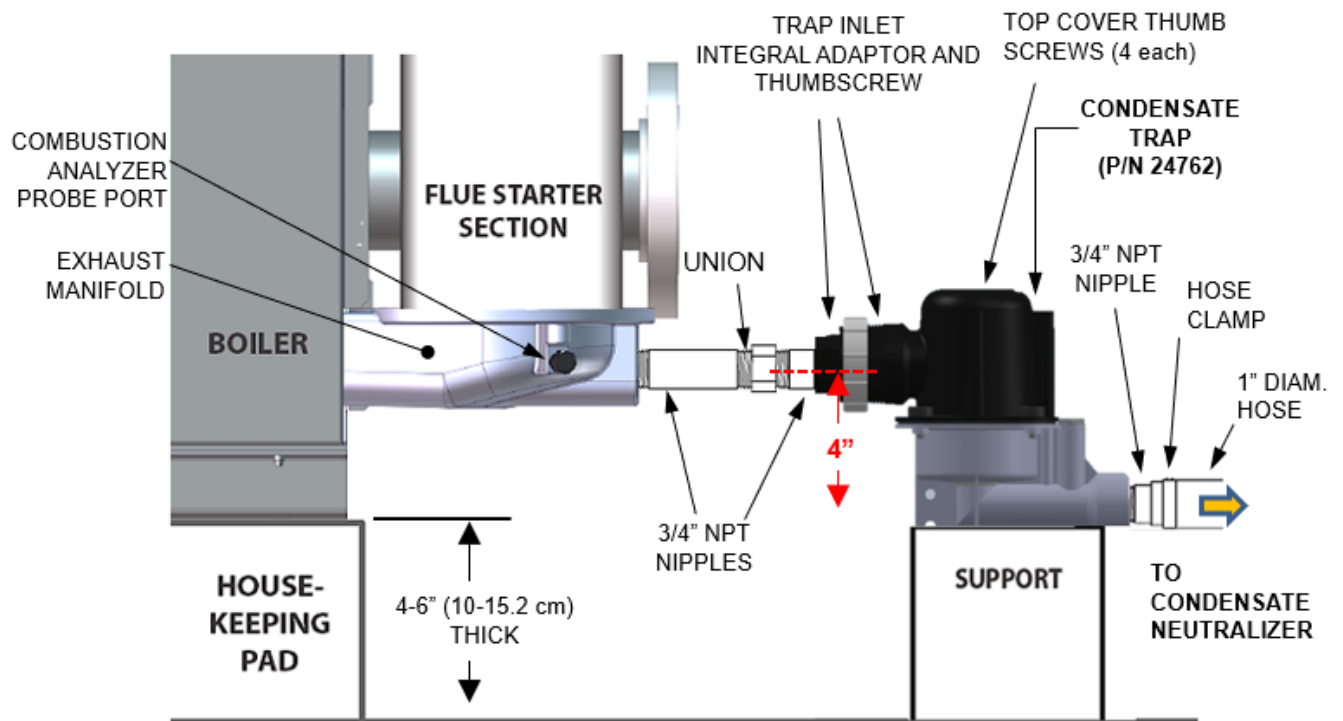

Figure 2-7a: BMK750/1000 Sample Condensate Trap Installation w/Condensate Trap P/N 24762

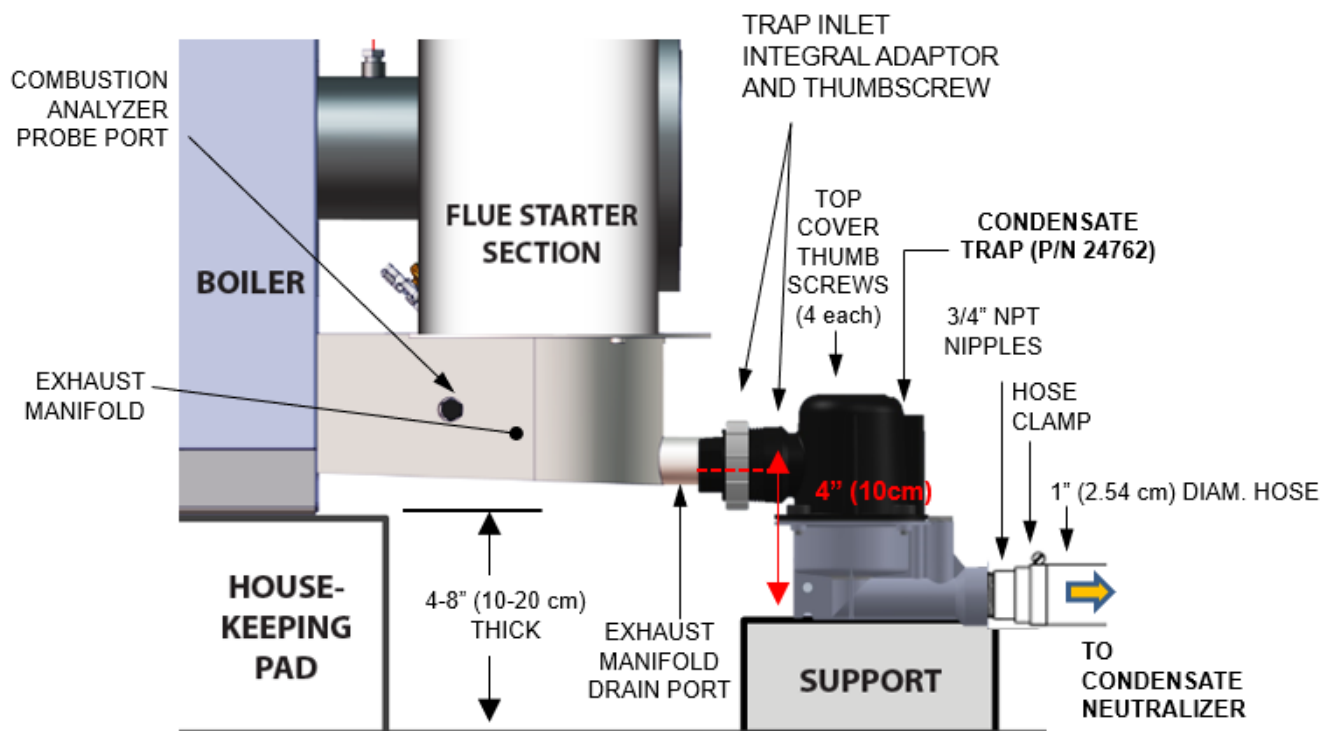

Figure 2-7b: BMK1500 – 6000 Sample Condensate Trap Installation w/Condensate Trap P/N 24762

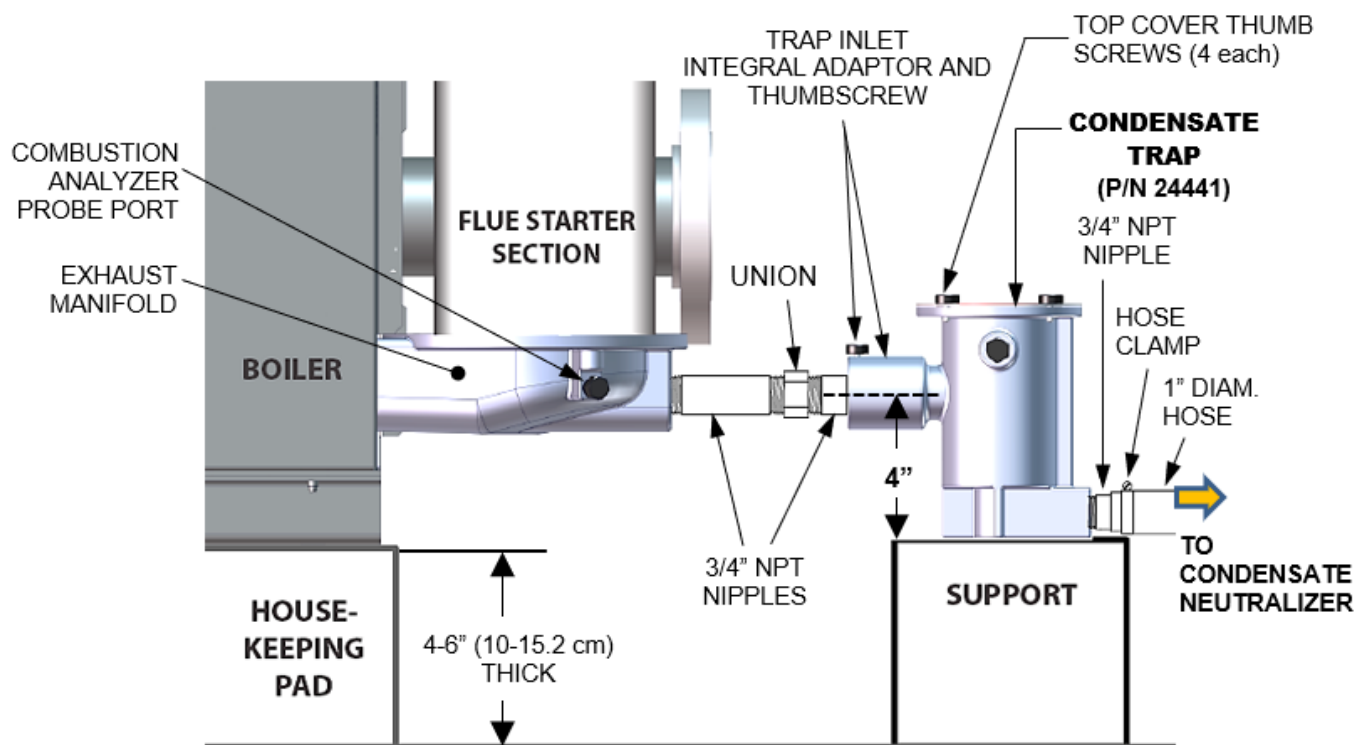

Figure 2-7c: BMK750/1000 Sample Condensate Trap Installation w/Condensate Trap P/N 24441

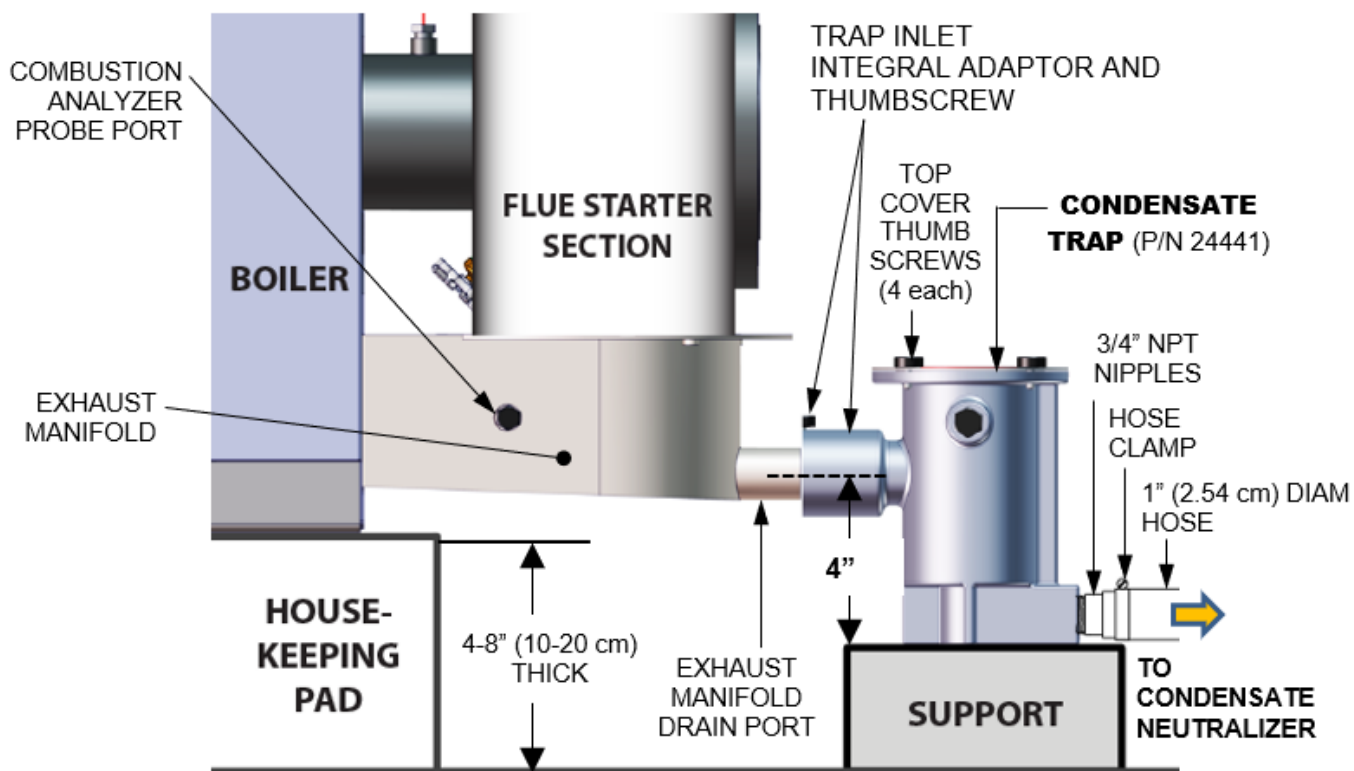

Figure 2-7d: BMK1500 – 6000 Sample Condensate Trap Installation w/Condensate Trap P/N 24441

SECTION 2 – INSTALLATION

2.11 Gas Supply Piping

AERCO’s *Benchmark Gas Supply Design Guide*, TAG-0047 (GF-2030) must be consulted prior to designing or installing any gas supply piping.

WARNING!

Never use matches, candles, flames or other sources of ignition to check for gas leaks.

CAUTION!

Many of the soaps used for gas pipe leak testing are corrosive to metals. Therefore, piping must be rinsed thoroughly with clean water after leak checks have been completed.

NOTE: Arrange all gas piping so it does not interfere with removal of any covers, inhibit service/maintenance, or restrict access between the unit and walls, or another unit.

BMK Model	Natural Gas Piping	Propane Piping
750 and 1000	1 inch (2.54 cm) in back of unit	Single Fuel: 1 inch (2.54 cm) in back of unit Dual Fuel: 3/4 inch (1.91 cm) in back of unit
1500 – 3000	2 inch (5.08 cm) on top of unit	1 inch (2.54 cm) on top of unit
4000 and 5000N	3 inch (7.62 cm) on top of unit	1-1/2 inch (3.81 cm) on top of unit
5000 and 6000	2 inch (5.08 cm) in back of unit 3-inch (7.62 cm) LGP in back of unit	1-1/2 inch (3.81 cm) on top of unit

2.11.1 Prior to installation

All pipes should be de-burred and internally cleared of any scale, metal chips or other foreign particles. Do *NOT* install any flexible connectors or unapproved gas fittings. Piping must be supported from the floor, ceiling or walls only and must not be supported by the unit.

A suitable piping compound, approved for use with natural gas, should be used. Any excess must be wiped off to prevent clogging of components.

To avoid unit damage when pressure testing gas piping, the unit must be isolated from the gas supply piping. A thorough leak test of all external piping must be performed using a soap and water solution or suitable equivalent. The gas piping used must meet all applicable codes.

2.11.2 Gas Supply Specifications

AERCO Benchmark Low NOx series boilers require a stable natural gas and propane input pressure. It must comply with the allowable gas inlet pressure range specified in the *Benchmark Gas Supply Design Guide* (TAG-0047, GF-2030).

2.11.3 External Gas Supply Regulator

An external gas pressure regulator is required on the gas inlet piping under most conditions (see, below). Regulators must conform to the specifications in the *Benchmark Gas Supply Design Guide* (TAG-0047, GF-2030).

NOTE: It is the customer’s responsibility to source and purchase the appropriate gas regulator. AERCO offers for sale an appropriate regulator, which may be ordered at the time of unit purchase or separately. Contact your AERCO sales representative for more information.

On all Benchmark models it is strongly recommended that the pressure regulator be installed a minimum distance of **10 pipe diameters** between the pressure regulator and the nearest downstream fittings (an elbow or the unit itself), and a minimum of **5 pipe diameters** between the pressure regulator and any upstream fitting, such as elbow or shutoff valve, as shown in Figure 2-8a – 2-8e, below.

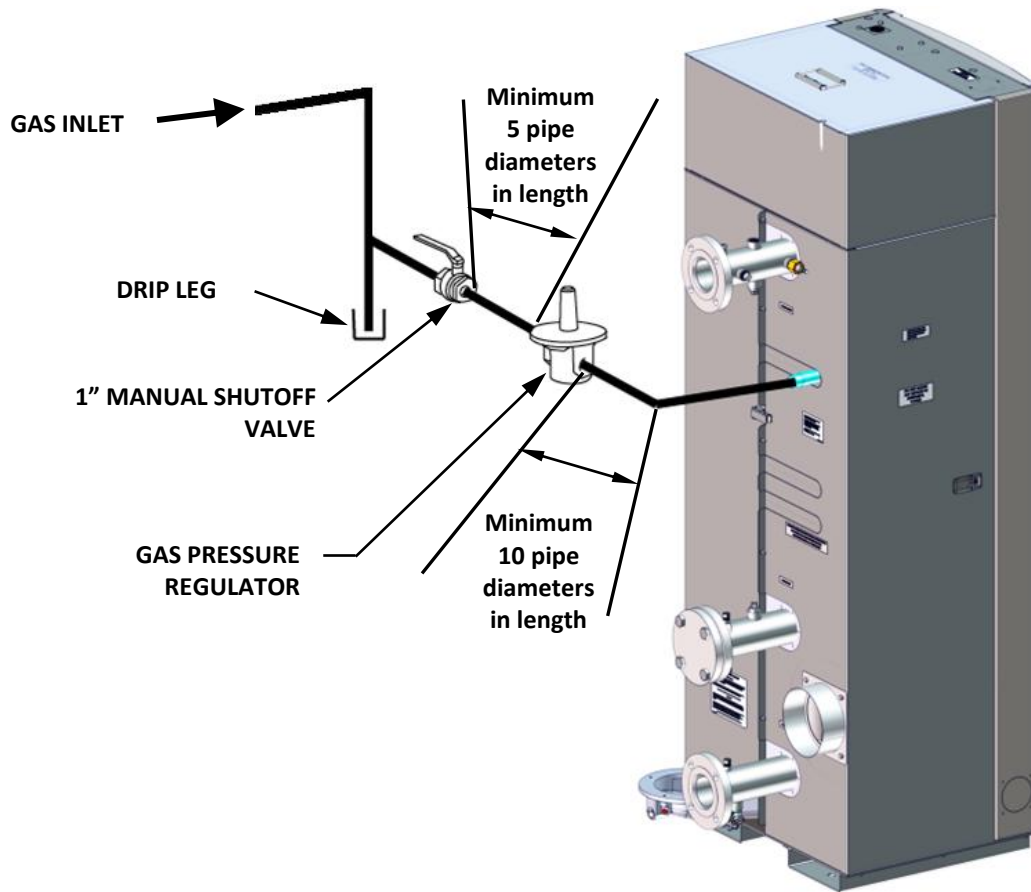

Figure 2-8a: BMK750/1000 Gas Regulator and Manual Shut-Off Valve

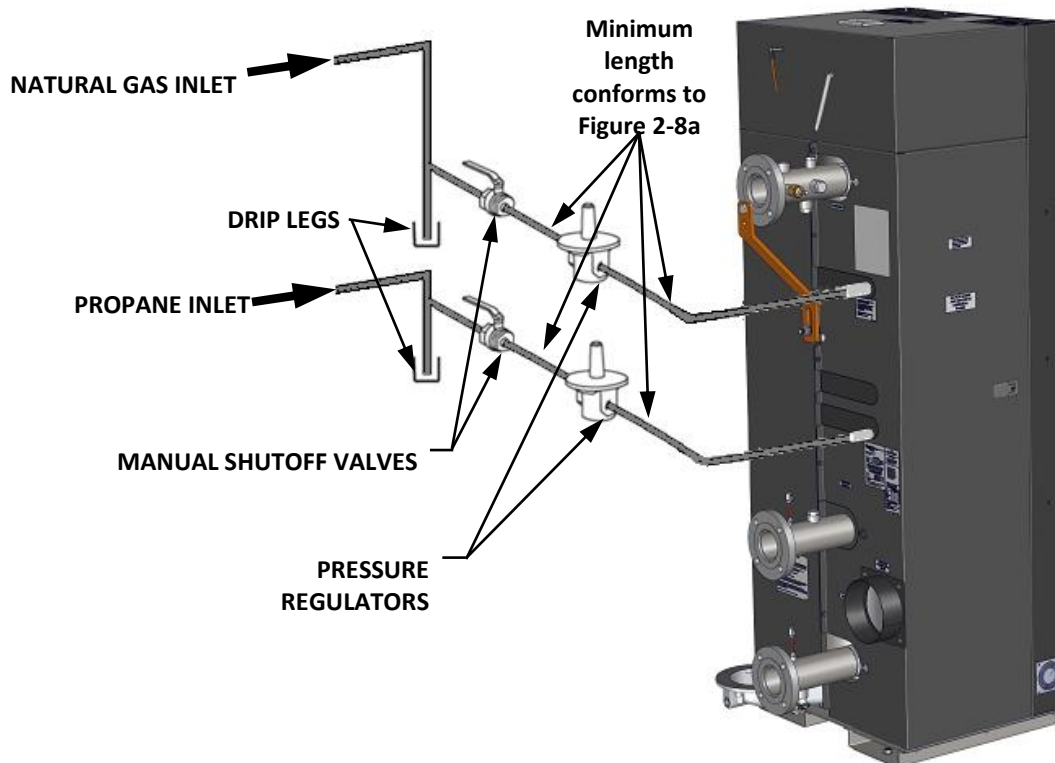

Figure 2-8b: BMK750/1000 Gas Regulator and Manual Shut-Off Valve – Dual Fuel

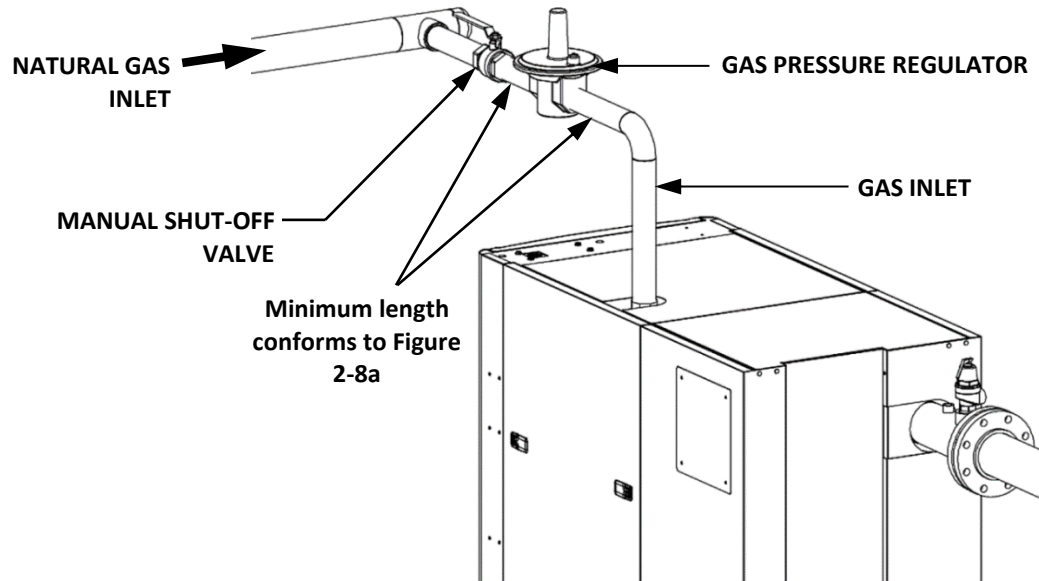
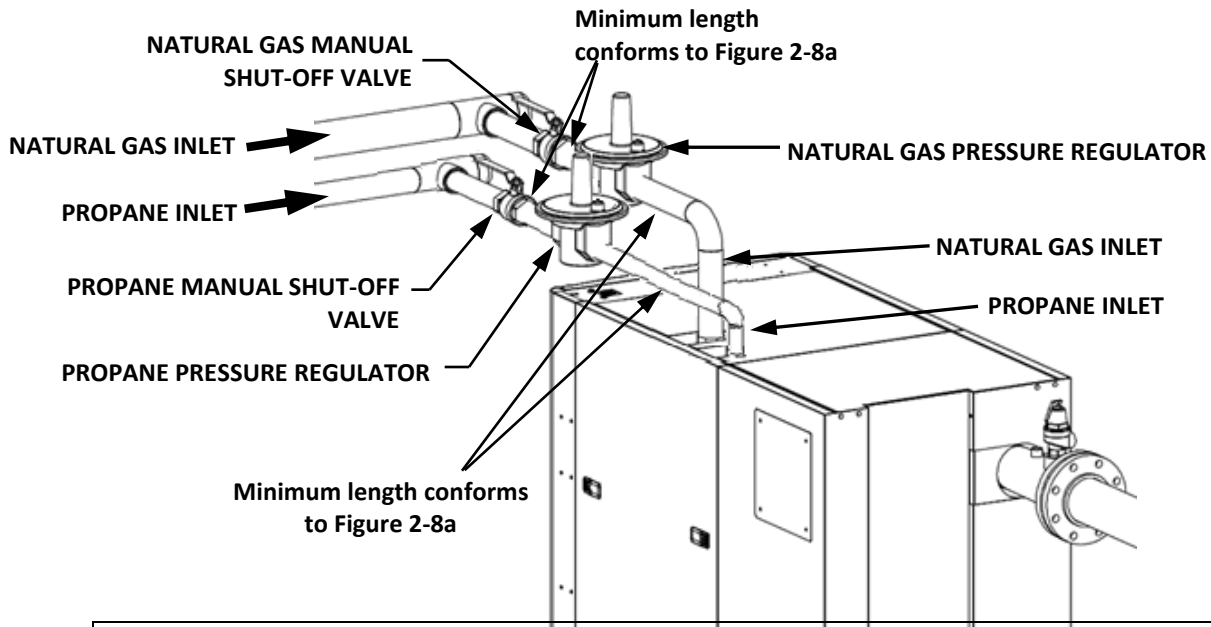

Figure 2-8c: BMK1500-5000N Gas Regulator and Manual Shut-Off Valve



NOTE: In propane-only units, the natural gas piping and components shown in Figure 2-8d and 8e are not present.

Figure 2-8d: BMK1500-5000N Gas Regulator and Manual Shut-Off Valve – Dual Fuel

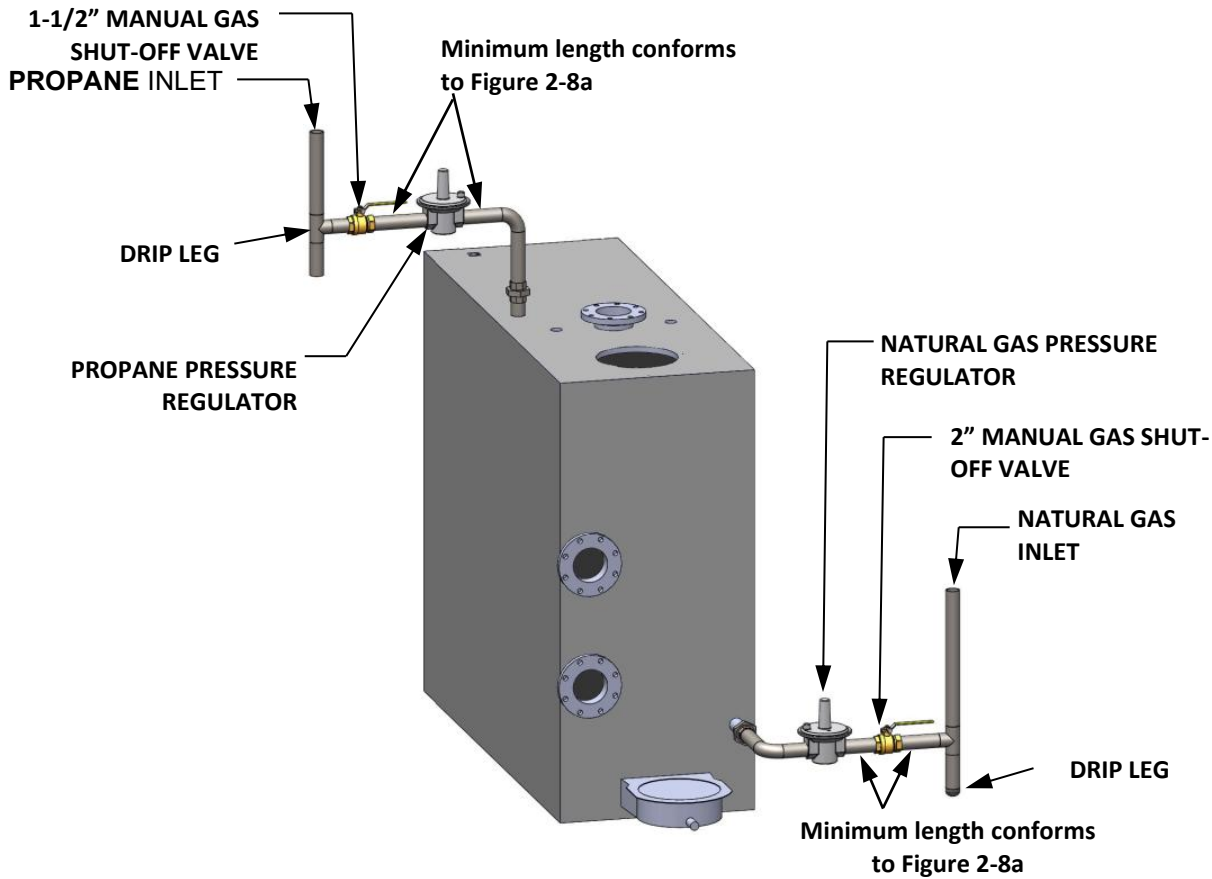

Figure 2-8e: BMK5000/6000 Manual Gas Shut-Off Valve Location – Dual Fuel

NOTE: Massachusetts Installations Only

For Massachusetts installations, an external gas supply regulator must be positioned as shown in Figure 2-8a – 2-8e, above. The gas supply regulator must be properly vented to outdoors. Consult your local gas utility for requirements concerning venting of the supply gas regulator.

2.11.4 Manual Gas Shutoff Valve

A manual shut-off valve must be installed in the gas supply line upstream of the boiler as shown in Figure 2-8a – 2-8e, above.

SECTION 2 – INSTALLATION

2.12 AC Electrical Power Wiring

AERCO’s *Benchmark Electrical Power Design Guide*, TAG-0048 must be consulted prior to connecting any AC power wiring to the unit.

2.12.1 Electrical Power Requirements

BMK Model	Voltage	Phase	Amperage
BMK750 – 1000 Domestic	120 V	1Ø / 60 Hz	15
BMK750 – 1000 International	220 V	1Ø / 50-60 Hz	20
BMK1500 – 2000 Domestic	120 V	1Ø / 60 Hz	20
BMK1500 – 2000 International	220 V	1Ø / 50-60 Hz	20
BMK2500 - 3000 Domestic	208 V	3Ø / 60 Hz	20
	460 V	3Ø / 60 Hz	15
BMK2500 - 3000 International	380-415 V	3Ø / 50-60 Hz	15
BMK4000 – 5000N Domestic	208V	3Ø / 60 Hz	40
	480V	3Ø / 60 Hz	20
BMK5000 - 6000 Domestic	208 V	3Ø / 60 Hz	30
	460 V	3Ø / 60 Hz	20
BMK5000 - 6000 Canada	575 V	3Ø / 60 Hz	20
BMK5000 - 6000 International	380-415 V	3Ø / 50-60 Hz	20

All power requirements are in the *Benchmark Electrical Power Design Guide* (TAG-0048).

2.12.2 Power Panel Locations

External AC power connection is made inside the Power Panel, located on the front of the unit, behind the unit’s removable front panel.

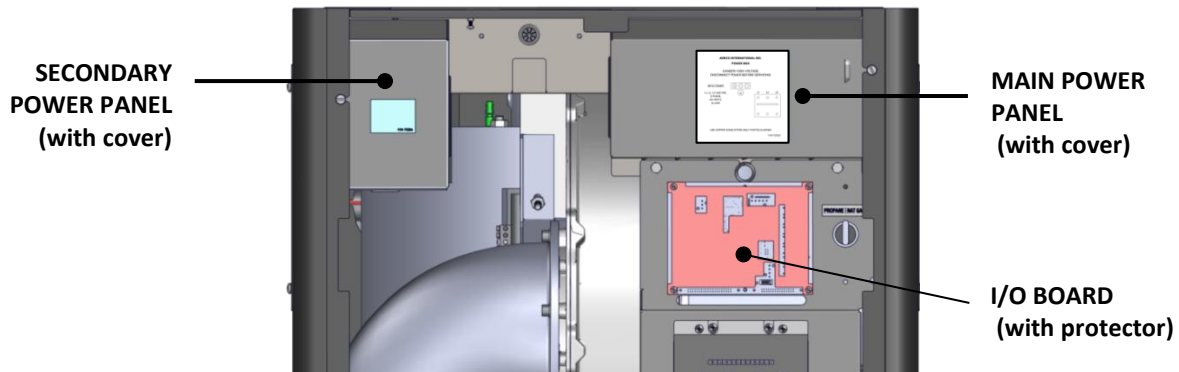

Figure 2-9: Power Panel – Shown with Cover in Place

The front cover of the Power Panel has a label showing the required AC power connections. Some representative labels are shown below.

Each unit must be connected to a dedicated electrical circuit. **NO OTHER DEVICES SHOULD BE ON THE SAME ELECTRICAL CIRCUIT AS THE BOILER.**

A switch must be installed on the electrical supply line, external to the unit, in an easily accessible location to quickly and safely disconnect electrical service. DO NOT attach the switch to sheet metal enclosures of the unit.

After placing the unit in service, the ignition safety shutoff device must be tested. If an external electrical power source is used, the installed boiler must be electrically bonded to ground in accordance with the requirements of the authority having jurisdiction. In the absence of such requirements, the installation shall conform to National Electrical Code (NEC), ANSI/NFPA 70 and/or the Canadian Electrical Code (CEC) Part I, CSA C22.1 Electrical Code.

SECTION 2 – INSTALLATION

2.12.3 Electrical Power Panel Internal Components

Remove the front panel to access the Power Panel. Run the electrical service through the opening above the Power Panel and make the connections to the Power Breaker in accordance to the Power Panel cover label (see Figure 2-9, above).

WARNING!
The power breaker shown does **NOT** remove power from the terminal blocks.

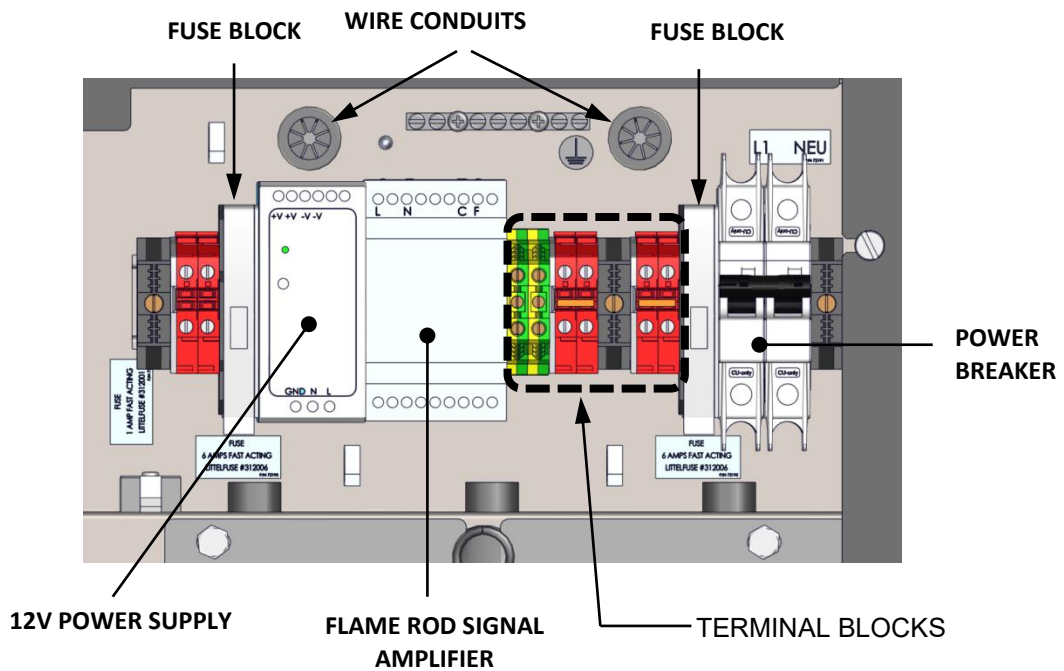

Figure 2-10a: BMK750 - 1500 110 V Power Panel

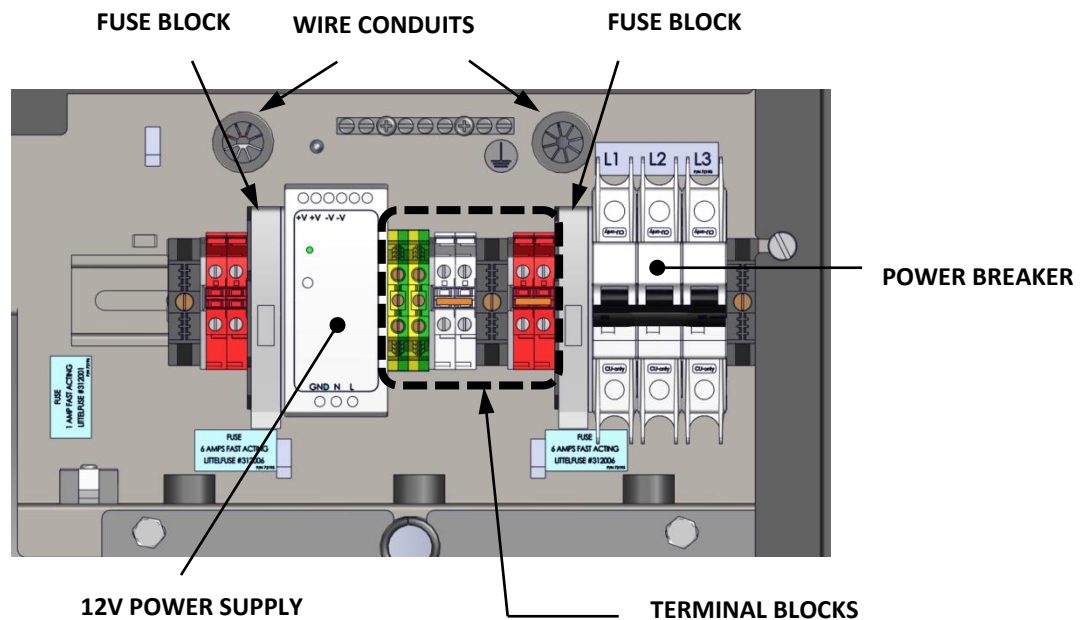

Figure 2-10b: BMK2500 – 6000 Power Panel Internal Components

SECTION 2 – INSTALLATION

NOTES:

- The 115V to 24V transformer provides power for the Edge Controller and the Sequencing Isolation Valve. It is mounted on the back side of the Main Power Panel. All other components in the Power Panel are mounted on a DIN rail on the front side of the panel.
- All electrical conduit and hardware must be installed so that it does not interfere with the removal of any unit covers, inhibit service/maintenance, or prevent access between the unit and walls or another unit.

2.13 Field Control Wiring – I/O Board

Each unit is fully wired from the factory with an internal operating control system. No field control wiring is required for normal operation. However, the Edge Controller used with your Benchmark unit does allow for some additional control and monitoring features. Wiring connections for these features are made on the Input/Output (I/O) board located behind the unit’s removable front panel, as shown in Figure 2-11.

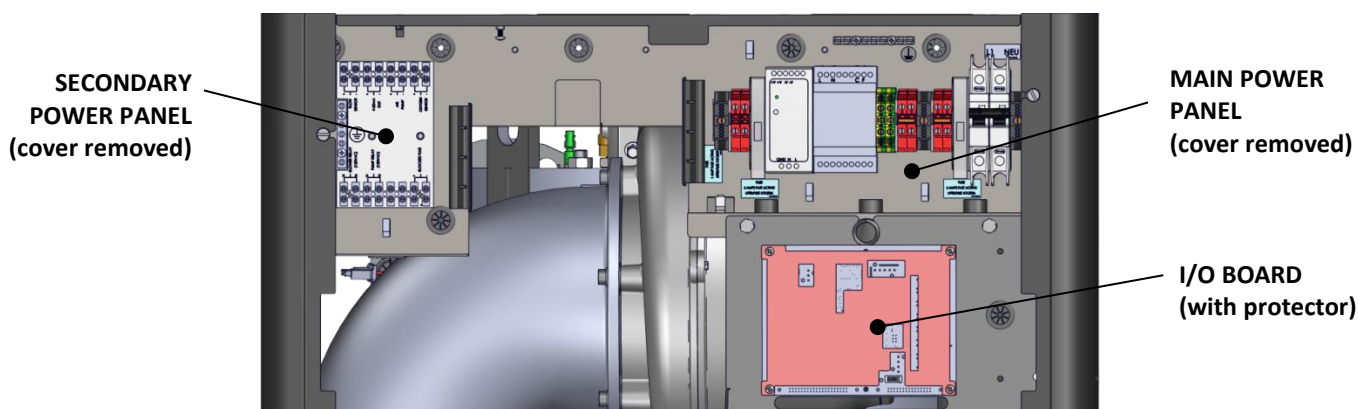

Figure 2-11: Power Panel and Input/Output (I/O) Board Location

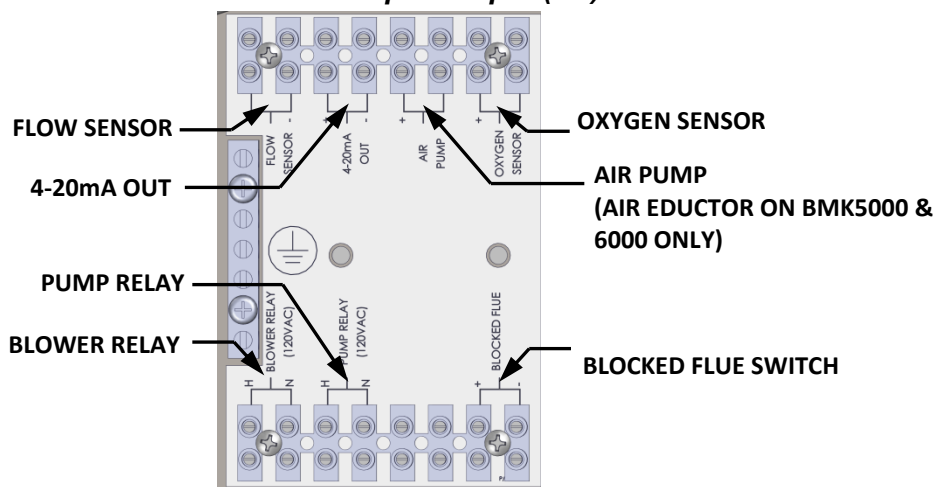

Figure 2-12: Secondary Power Panel Terminals

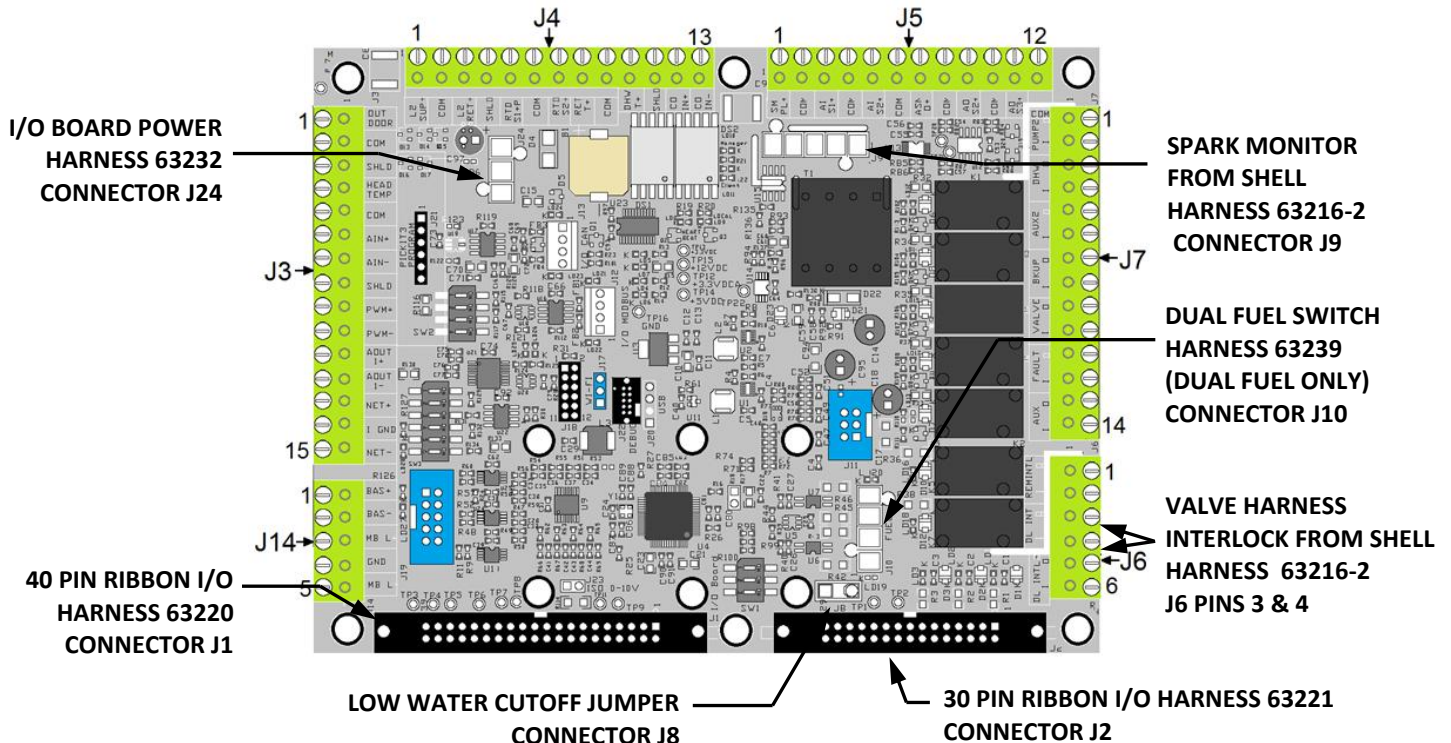
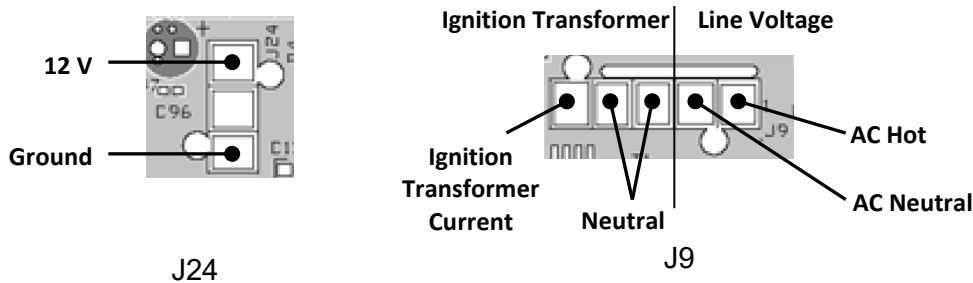

Figure 2-13: I/O Board Cable Connections

2.13.1 I/O Board Connections

The I/O board contains the terminal listed below, arranged on removable, named connector strips J3 through J7 and J14, plus Molex connectors for unit harnesses. The maximum gauge of wires connecting to the I/O board is 14.



NOTE: To facilitate making the connections, this strip can be lifted off the I/O board. The entire strip is then remounted on the I/O board after all connections have been made. If a connector strip is removed, it must be re-mounted in its original orientation (connecting wires arranged around the *outside* perimeter of the I/O board).

Connector Strip J3 Terminals		
Pin #	Name	Description
1	Outside Temp +	Connections to Outside Air Temperature (OAT) sensor (P/N 61048). Used on Manager and Backup Manager units. Required for the OUTDOOR RESET mode of operation. To enable this mode, go to Main Menu → Advanced Setup → Unit → Application Configuration and set SH Operating Mode to Outdoor Reset , then configure the related parameters.
2	Outside Temp -	
3	Shield	Connection to the shield from any cable.

SECTION 2 – INSTALLATION

Connector Strip J3 Terminals		
Pin #	Name	Description
4	Supply Header +	Connection to the Supply Header temperature sensor (2 wire sensor P/N 24410 , or 4 wire sensor P/N 61058) for: <ul style="list-style-type: none"> • Main Loop (in a Variable-Primary application) • Secondary Loop (in a Primary-Secondary application) • Loop 1 (in a Multi-application) Typically, used on Manager and Backup Manager units. For more information, refer to the <i>Benchmark Boiler Application Guide</i> (TAG-0019)
5	Supply Header –	
6	Remote Analog In +	Connection to the Analog Remote Signal, if Operating Mode = Remote Setpoint. Used on Manager and Backup Manager units.
7	Remote Analog In –	
8	Shield	Connection to the shield from any cable.
9	PWM Input +	Reserved for future use.
10	PWM Input –	
11	BLR V.S. Pump +	Reserved for future use. Boiler Variable Speed Pump. Connection for the VFD signal to the pump,
12	BLR V.S. Pump –	
13	BST/WHM RS485 +	Dedicated to internal communication between units in a BST or WHM system. ACS (legacy) panel should also be connected to this terminal.
14	RS485 Iso Gnd	
15	BST/WHM RS485 -	

Connector Strip J4 Terminals		
Pin #	Name	Description
1	Supply Loop 2	In a multiple application configuration, connection to the 2 nd loop <u>supply</u> header temperature sensor.
2	Sensor Ground	Ground connection for Supply Loop 2
3	Return Loop 2	In a multiple application environment, connection to the 2 nd loop <u>return</u> header temperature sensor.
4	Shield	Connection to the shield from any cable.
5	RTD Spare 1	Reserved. Spare temp sensor
6	Sensor Ground	Ground connection for RTD Spare 1
7	RTD Spare 2	Reserved. Spare temp sensor
8	Return Header	Connection to the Supply Header temperature sensor (2 wire sensor P/N 24410 , or 4 wire sensor P/N 61058) for: <ul style="list-style-type: none"> • Main Loop (in a Variable-Primary application) • Secondary Loop (in a Primary-Secondary application) • Loop 1 (in a Multi-application) Typically, used on Manager and Backup Manager units. For more information, refer to the <i>Benchmark Boiler Application Guide</i> (TAG-0019)
9	Sensor Ground	Ground connection for Return Header Temp sensor
10	DHW Temp	Connect the DHW tank temperature or DHW Loop Supply Temperature sensor
11	Shield	Connection to the shield from any cable.
12	CO/Analog In +	Reserved for future use
13	CO/Analog In -	

Connector Strip J5 Terminals		
Pin #	Name	Description
1	Spare Analog In 3 +	Connection to one of the following signals: <ul style="list-style-type: none"> • SmartPlate Valve input • Swing V1 feedback • Swing V2 Feedback
2	Spare Analog In 3 -	
3	Spare Analog In 1 +	
4	Spare Analog In 1 -	
5	Spare Analog In 2 +	

SECTION 2 – INSTALLATION

Connector Strip J5 Terminals		
Pin #	Name	Description
6	Spare Analog In 2 -	<ul style="list-style-type: none"> VS Pump Feedback (Variable Speed Pump Feedback) Remote Setpoint 2 DHW VSP Fdbk To assign/program its function, go to the Controller’s Main Menu → Advanced Setup → Ancillary Devices → Analog Inputs , then set the Input parameter to Spare Analog In 1, Spare Analog In 2, or Spare Analog In 3 .
7	Spare Analog Out 1 +	Connection to one of the following signals: <ul style="list-style-type: none"> Fire Rate Cascade Valve To assign/program its function, go to the Controller’s Main Menu → Advanced Setup → Ancillary Devices → Analog Outputs , then set the Output parameter to Spare Analog Out 1 .
8	Spare Analog Out 1 -	
9	DHW V.S. Pump +	Connection to the VFD signal to a DHW Variable Speed Pump, installed between: <ul style="list-style-type: none"> The 4-port buffer tank and SmartPlate The boiler and SmartPlate in a 2-port buffer tank configuration.
10	DHW V.S. Pump -	
11	Spare Analog Out 3 +	Connection to the Fire Rate signal. To assign/program its function, go to the Controller’s Main Menu → Advanced Setup → Ancillary Devices → Analog Outputs , then set the Output parameter to Spare Analog Out 3 .
12	Spare Analog Out 3 -	

Connector Strip J6 Terminals		
Pin #	Name	Description
1	Remote Interlock Out	Connection to an auxiliary device interlock, such as louver open feedback or flow sensor.
2	Remote Interlock Return	
3	Delayed Interlock 1 Out	Connection to an auxiliary device interlock that requires a delay before the plant starts firing.
4	Delayed Interlock 1 Return	
5	Delayed Interlock 2 Out	Connection to an auxiliary device interlock that requires a delay before the plant starts firing.
6	Delayed Interlock 2 Return	

Connector Strip J7 Terminals		
Pin #	Name	Description
1	Spare 2 Relay N.O.	Connection to an auxiliary device enable/disable signal, such as: <ul style="list-style-type: none"> System Pump Summer Pump Pump 2 Louver Louver 2 Damper Other To assign/program its function, go to the Controller’s Main Menu → Advanced Setup → Ancillary Devices → Relays , then set the Relay to Spare 2 Relay and the Name to one of the above devices.
2	Spare 2 Relay Com	
3	DHW Pump Relay N.O.	Connection to a DHW Pump enable/disable signal.
4	DHW Pump Relay Com	
5	V2/Spare 1 Relay N.O.	Connection to an auxiliary device enable/disable signal, such as:

SECTION 2 – INSTALLATION

Connector Strip J7 Terminals		
Pin #	Name	Description
6	V2/Spare 1 Relay Com	<ul style="list-style-type: none"> • Swing Valve 2 • System Pump • Summer Pump • Pump 2 • Louver • Louver 2 • Damper • Other <p>To assign/program its function, go to the Controller's Main Menu → Advanced Setup → Ancillary Devices → Relays, then set the Relay to V2/Spare 1 Relay and the Name to one of the above devices.</p>
7	Reserve Relay N.O.	Connection to a reserve/backup boiler enable/disable signal.
8	Reserve Relay Com	
9	Swing Valve 1 Relay N.O.	Connection to a Swing Valve 1 enable/disable signal.
10	Swing Valve Relay Com	
11	Fault Relay N.O.	Connection to a Fault/Remote Alarm enable/disable signal.
12	Fault Relay Com	
13	Aux Relay N.O.	Connection to an auxiliary device enable/disable signal.
14	Aux Relay Com	

Connector Strip J14 Terminals		
Pin #	Name	Description
1	BAS RS485 +	Connection to the building automation system (BAS) network (Modbus RTU, BACnet MSTP). For IP network, use the Ethernet port.
2	BAS RS485 -	
3	RS485 Local +	Reserved for internal use only
4	RS4585 Ground	
5	RS485 Local -	

2.14 Flue Gas Vent Installation

AERCO's *Benchmark Venting and Combustion Air Design Guide*, TAG-0022 must be consulted before any flue or combustion air venting is designed or installed. Suitable, U/L approved, positive pressure, watertight vent materials **MUST** be used for safety and UL certification.

Once you have selected the vent material, enter that material in the Edge Controller:

1. Go to: **Main Menu** → **Advanced Setup** → **Unit** → **Unit Settings**.
2. Find the **Vent Type** parameter.
3. Set the value of this parameter to match your vent material: PVC, Polypro or Stainless Steel. This sets the exhaust temperature limits. Note, PVC is not allowed in the state of Massachusetts.

Because the unit is capable of discharging low temperature exhaust gases, **the flue must be pitched back towards the unit a minimum of 1/4" per foot (0.64 cm per 0.3 m)** to avoid any condensate pooling and to allow for proper drainage.

While there is a positive flue pressure during operation, the combined pressure drop of vent and combustion air systems **must not exceed 140 equivalent feet (42.7m) or 0.8" W.C. (199 Pa)**. Fittings as well as pipe lengths must be calculated as part of the equivalent length. For a natural draft installation, **the draft must not exceed -0.25" W.C. (-62 Pa)**. These factors must be planned into the vent installation. If the maximum allowable equivalent lengths of piping are exceeded, the unit will not operate properly or reliably.

SECTION 2 – INSTALLATION

2.14.1 MASSACHUSETTS INSTALLATIONS

For Massachusetts installations, the following companies provide vent systems that conform to all applicable requirements for installations within the Commonwealth of Massachusetts. Contact information is as follows:

<p>Selkirk Corporation - Heatfab Division 130 Industrial Blvd. Turners Falls, MA 01376 Phone: 1-800-772-0739 www.heatfab.com</p>	<p>Watertown Supply 33 Grove St. Watertown, MA 02472 Phone: (617) 924-2840 www.watertownsupply.com</p>
<p>Glover Sheet Metal, Inc. 44 Riverdale Ave. Newton, MA 02485 Phone: (617) 527-8178 www.gloversheetmetal.com</p>	<p>Emerson Swan Co Engineering Products Department 300 Pond St. Randolph, MA 02368 Phone 781-986-2555 Fax 781-986-2027 www.emersonswan.com</p>

2.15 Combustion Air

The *Benchmark Venting and Combustion Air Design Guide*, TAG-0022 (GF-2050) MUST be consulted before any inlet air venting is designed or installed. Air supply is a direct requirement of ANSI 223.1, NFPA-54, CSA B149.1 and local codes. These codes should be consulted before a permanent design is determined.

The combustion air must be free of chlorine, halogenated hydrocarbons, other chemicals that can become hazardous when used in gas-fired equipment and other combustion products. Common sources of these compounds are swimming pools, degreasing compounds, plastic processing, and refrigerants. Whenever the environment contains these types of chemicals, combustion air MUST be supplied from a clean area outdoors for the protection and longevity of the equipment and warranty validation.

If combustion air is supplied directly to the unit(s) though air duct(s), see section 2.13.1 below.

If combustion air is not supplied through air ducts, it must be supplied to the unit(s) through two permanent openings. These two openings must have a free area of **not less than one square inch (6.5 cm²) for each 4000 BTUs (1.17 kW) input for each unit**. The free area must take into account restrictions such as louvers and bird screens.

For installations within Canada, refer to CSA B149.1-10, sections 8.4.1 and 8.4.3.

2.15.1 DUCTED COMBUSTION AIR

For ducted combustion air installations, the air ductwork must be attached directly to the air inlet connection on the sheet metal enclosure. Consult the *Benchmark Venting and Combustion Air Design Guide*, TAG-0022 when designing combustion air ducting.

In a ducted combustion air application, the combustion air ducting pressure losses must be taken into account when calculating the total maximum allowable venting run. When using the unit in a ducted combustion air configuration, the minimum diameter connection at the unit is:

TABLE 2-4: Air Duct Minimum Diameter	
Benchmark Model	Duct Diameter
BMK750 – BMK1500	6-inch (15.2 cm) diameter connection
BMK2000 – BMK3000	8-inch (20.3 cm) diameter connection
BMK4000 and 5000N	10-inch (25.4 cm) diameter connection
BMK5000 & BMK6000	14-inch (35.6 cm) diameter connection

SECTION 2 – INSTALLATION

2.16 BST Sequencing Isolation Valve Installation

All Benchmark units are pre-wired with a connection for an optional motorized external sequencing isolation valve (P/N **92084-TAB**). This valve is an integral component of AERCO's on-board Boiler Sequencing Technology (BST) solution. BST allows sites with multiple boilers to have one boiler, designated the "Manager," manage the other boilers at the site, designated as "Clients" in such a way that the efficiency of the entire boiler array is maximized.

When operated with the BST system, the BST Manager controls its own isolation valve and sends signals to BST Clients to open or close their isolation valves. After boiler load is satisfied, its isolation valve remains opens for a time interval defined in the **SH Valve Close Delay** parameter (see [Main Menu](#) → [Advanced Setup](#) → [BST Cascade](#) → [Operating Controls](#) → [Sequencing Controls](#); default = 1 minute), then closes.

Once system load is satisfied and all Client units have stopped firing, the BST Manager opens the isolation valves of all Client units. The implementation of BST, and the installation and use of this valve, is optional. However, **when BST is implemented, use of this valve is strongly recommended.**

Installation consists of installing the sequencing isolation valve in the hot water outlet pipe and then connecting it to the pre-wired connector on the shell harness, as described below.

NOTE: The Sequencing Isolation Valve control is a pre-programmed valve, available only from AERCO. It is installed only on boilers that are part of a Boiler Sequencing Technology group. Refer to Section 7: *Boiler Sequencing Technology* in the *Benchmark -Edge: OPERATION-SERVICE Manual (OMM-0137)* for configuration instructions.

Sequencing Isolation Valve Installation Instructions

1. Install the sequencing isolation valve in the boiler's hot water outlet pipe.

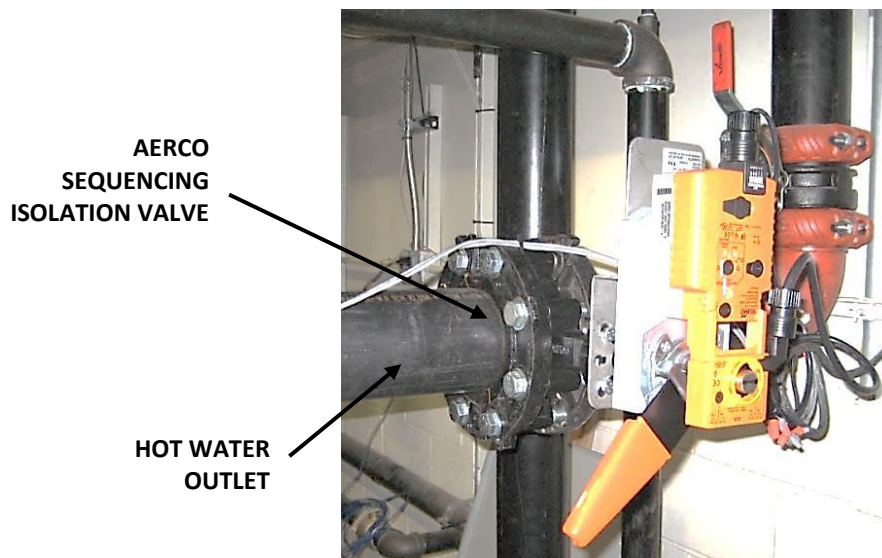

Figure 2-14: Sequencing Isolation Valve Installed

2. Find the grey cable inside the unit's enclosure with the unused Molex connector with a cap containing a jumper wire inserted in it (the jumper wire allows units that do not have a sequencing isolation valve to operate normally). The other end is connected to the I/O board and to a power supply.

SECTION 2 – INSTALLATION

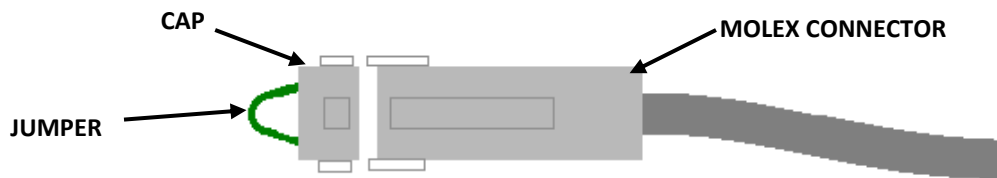

Figure 2-15a: Sequencing Isolation Valve Molex Connector and Jumper Wire

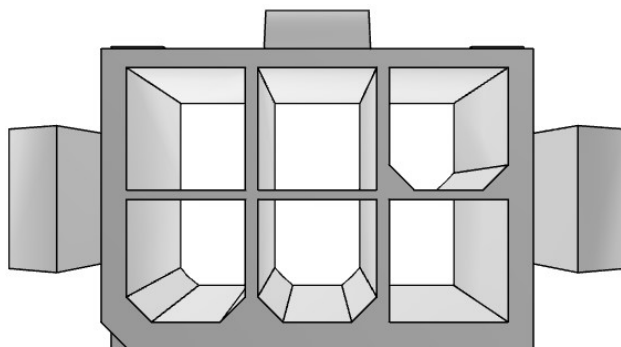

Figure 2-15b: Sequencing Isolation Valve Molex Connector and Jumper Wire (front view)

Isolation Valve Harness		
Wire #	Color	Signal
1236	Black	24V Common
1237	Red	24V Hot
1238	White	Valve analog input
1239	Green	Valve analog feedback
1240	Black	Delayed interlock
1241	Black	

NOTE: Signal from boiler is 0-10V, with default setting of 10V (white wire # 1238) when the valve is supposed to be closed.

3. Remove and dispose of the cap with jumper wire attached.
4. Plug the Molex connector into the sequencing isolation valve’s connector.
5. When the Sequencing Isolation Valve is used, the Controller’s **Auxiliary Delay** setting must be set to 120 seconds. Go into the Controller’s **Main Menu → Advanced Setup → Ancillary Device → Interlocks** screen and set the **Auxiliary Delay** parameter to **120**.

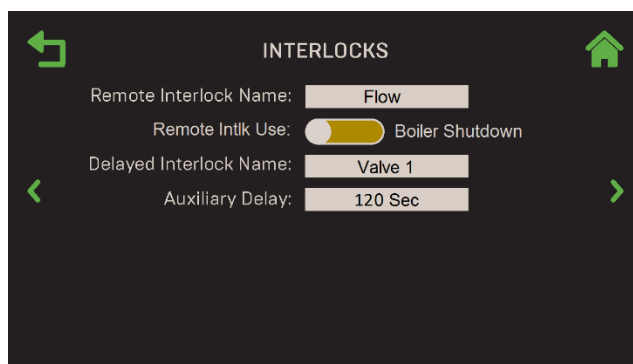

Figure 2-16: Interlocks Screen – Auxiliary Delay Parameter

SECTION 2 – INSTALLATION

2.17 Boiler Pump Relay

The Benchmark’s power panel includes a secondary output board with a pump relay that is designed to operate a boiler pump. This relay provides 120VAC with a maximum pilot duty of 3 amps. If the pump power requirement under all conditions is greater than 3 amps, it is required to use this relay to activate the pump through an intermediate relay with a higher power.

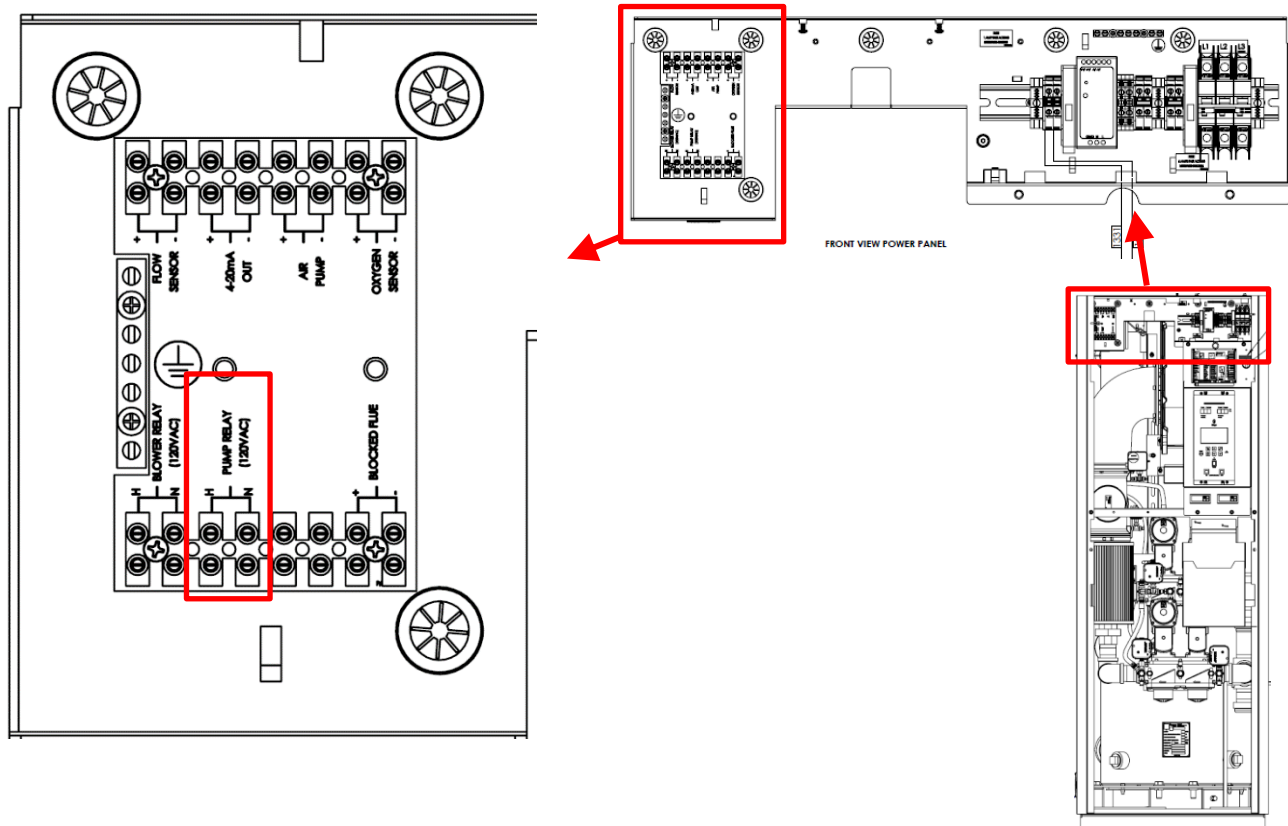

Figure 2-17: Boiler Pump Relay

The Pump Delay Timer feature allows the user to keep the pump running for up to 30 minutes after the boiler has shut down and the demand is satisfied. To enable this feature, go to **Main Menu → Advanced Setup → Ancillary Devices → Relays** and set the **Pump Off Delay** setting to the desired delays time.

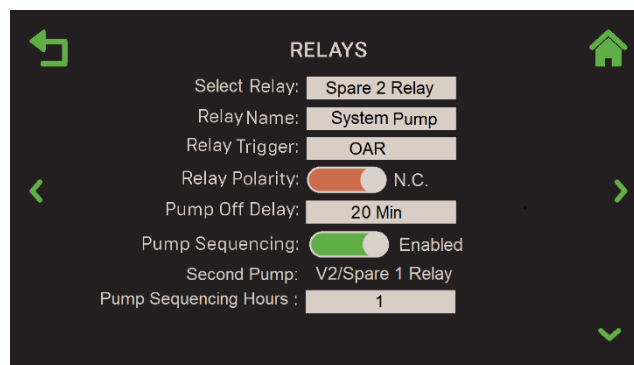

Figure 2-18: Relays Screen

SECTION 2 – INSTALLATION

2.18 Next Steps

Once the unit is physically installed per the instructions above, the next steps are:

- Optionally, implement the onAER option, which allows your unit to be monitored remotely. To implement this option, complete the instructions in the next section, *onAER Setup*.
- Start the unit for the first time and perform the combustion calibration procedure. For instructions, see the *Benchmark-Edge [i] Operation and Service Manual, OMM-0137, Section 4: Initial Startup*.

SECTION 3: ONAER SETUP

3.1 Introduction

AERCO has taken precautions to make onAER secure for both the customer's heating equipment and networks. The onAER feature lets AERCO boilers be monitored remotely in one of two ways:

- **Through an Ethernet cable from the site's network.** This is plugged into the Ethernet jack in the left side of the Edge Controller.
- **Wirelessly via Wi-Fi.** This solution requires the purchase and installation of the optional AERCO Wi-Fi module (P/N **24526-1**). This module is then connected directly to the boiler's I/O board, eliminating the need for an Ethernet cable.

The sections below provide instructions for implementing only the first option, enabling communication through an Ethernet cable connected to the site's network. If you ordered a Benchmark boiler with the Wi-Fi module, it is included in a separate container inside the unit's shipping container. The instructions for installing both the Wi-Fi module are in Technical Instruction document TID-0178, included with the Wi-Fi module.

If you did not order the Wi-Fi module but are now interested in it, contact your AERCO representative and ask about purchasing the Wi-Fi module (P/N **24526-TAB**).

Before onAER can be used, it must be enabled. Go to: **Main Menu → Advanced Setup → Comm & Network → onAER.**

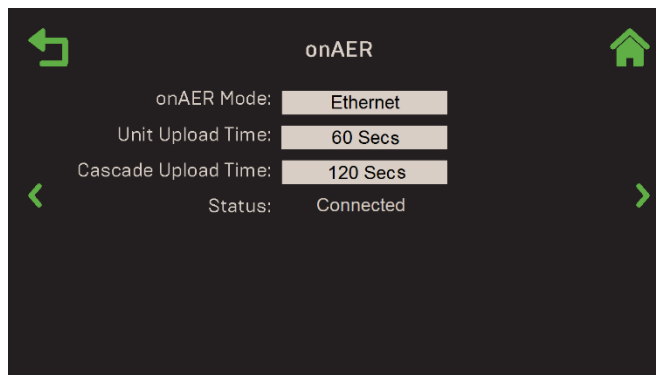

Figure 3-1: onAER Screen

1. Set the **onAER Mode** parameter to one of the following:
 - **Ethernet:** Requires an Ethernet cable plugged into the Controller. See next section.
 - **Wi-Fi:** Requires the AERCO Wi-Fi module (P/N 24526-TAB) to be installed on the unit; see the *onAER Wi-Fi Module Installation Guide* (TID-0178) for instructions.
 - **Wiznet:** This option intended for units on which the Edge Controller was installed as a replacement for the C-More Controller.
2. Once enabled, the following additions parameters appear:
 - **Unit Upload Time:** Determines how frequently unit data will upload to the server, in seconds. This will be split between unit data and cascade data (Manager unit only). (Range: 30 to 9999)
 - **Cascade Upload Time:** Determines how cascade data will upload to the server, in seconds. (Range: 60 to 9999)
 - **Status:** Displays the communication interface status, which varies depending on the interface selected in Step 2.

3.1.1 Connecting the Ethernet Cable

1. Connect a CAT 5 or better Ethernet cable to the wall jack or box provided at the site.
2. Route the Ethernet cable to the left side of the Edge Controller, avoiding hot locations.
3. Plug the Ethernet cable into the Edge Controller's Ethernet jack (see Figure 3-1).

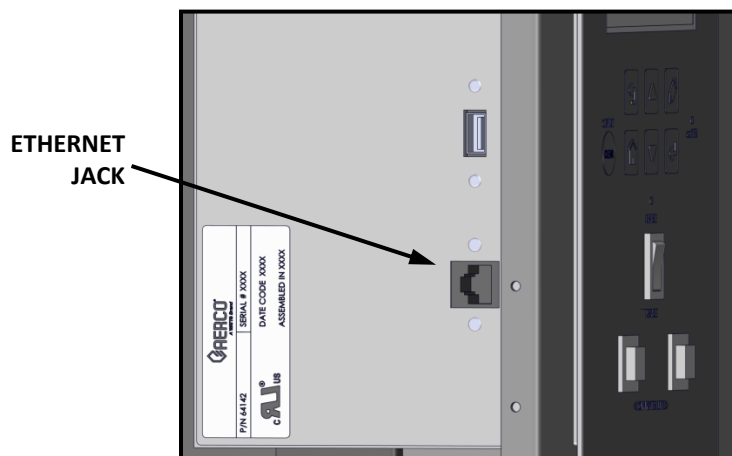

Figure 3-2: Edge Controller – Left Side View

3.1.2 Confirming the Ethernet Connection

Refer to Figure 3-3, below, and complete the following instructions to confirm that the Ethernet cable connection is working.

1. Powered the unit on and look for the green LED on the Controllers front face above the onAER soft-key.
2. If the green LED is blinking periodically, there is normal communication with the network.

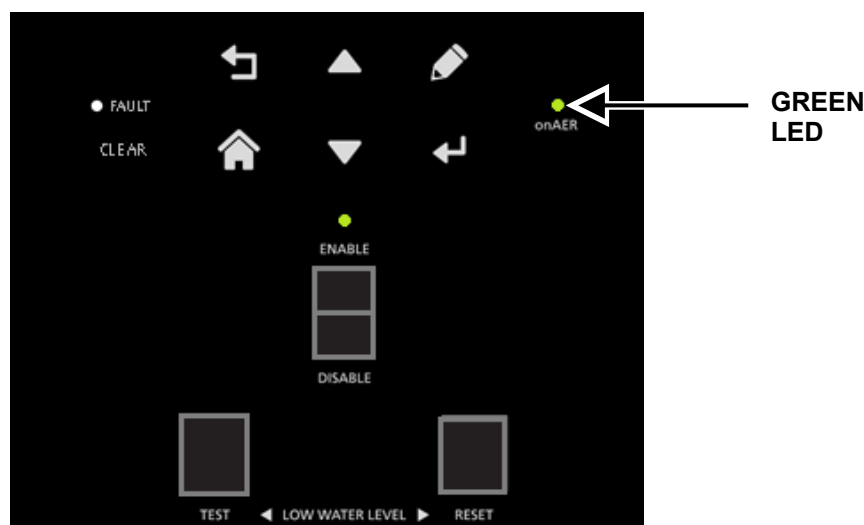

Figure 3-3: Edge Controller Front Face – Ethernet Indicator LED

3.1.3 Confirm Ethernet DHCP Configuration

Once you have confirmed that the Ethernet connection is working, complete the following steps to confirm that the connection is active.

1. Connect your computer to the network jack that will be used by the Edge Controller. Your computer should be configured to automatically get a network address. Boot or reboot your computer.
2. Open a web browser and go to www.google.com.
3. Confirm that you can access the Google home page without entering a password, which confirms that the connection is active, provides DHCP addresses, and allows access without a password.

NOTE: Static addresses are not required or recommended by AERCO. Reserved addresses are a simpler solution.

Appendix A: Dimensional and Clearance Drawings

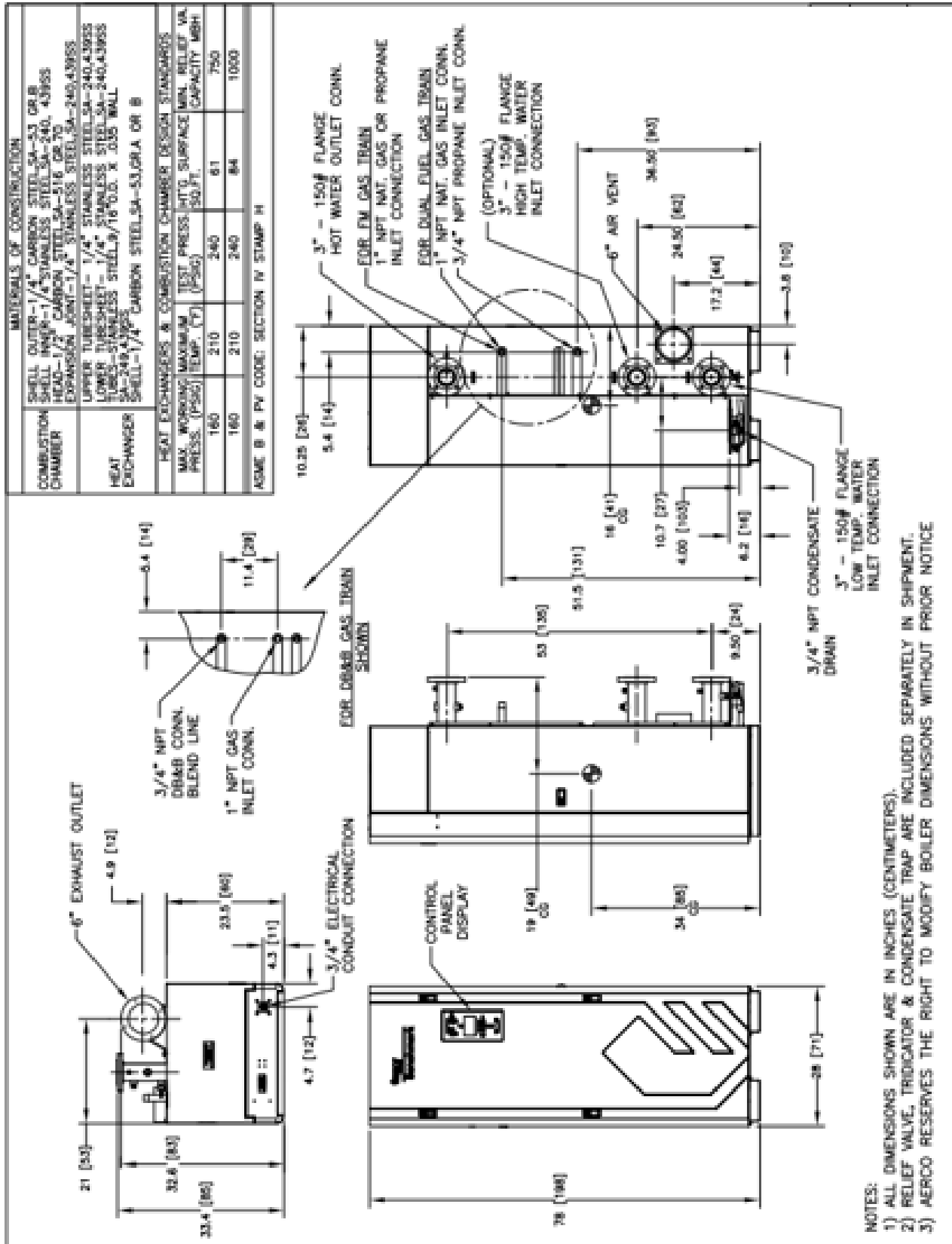

NOTES:
 1) ALL DIMENSIONS SHOWN ARE IN INCHES (CENTIMETERS).
 2) RELIEF VALVE, TRIDICATOR & CONDENSATE TRAP ARE INCLUDED SEPARATELY IN SHIPMENT.
 3) AERCO RESERVES THE RIGHT TO MODIFY BOILER DIMENSIONS WITHOUT PRIOR NOTICE

Benchmark 750/1000 Dimension Drawing AP-A-891 rev M

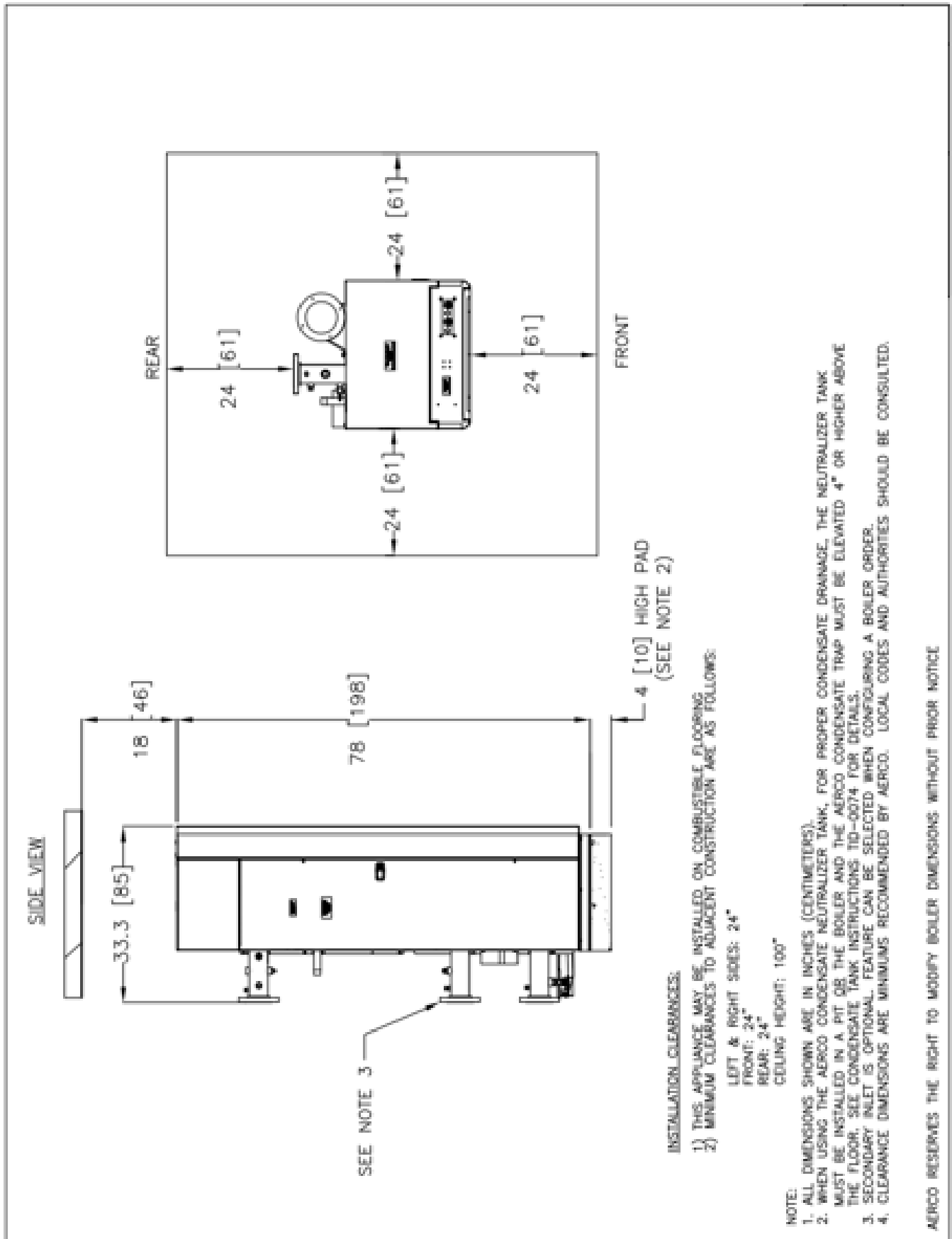

Benchmark 750/1000 Single Unit Clearance Drawing SD-A-871 rev D

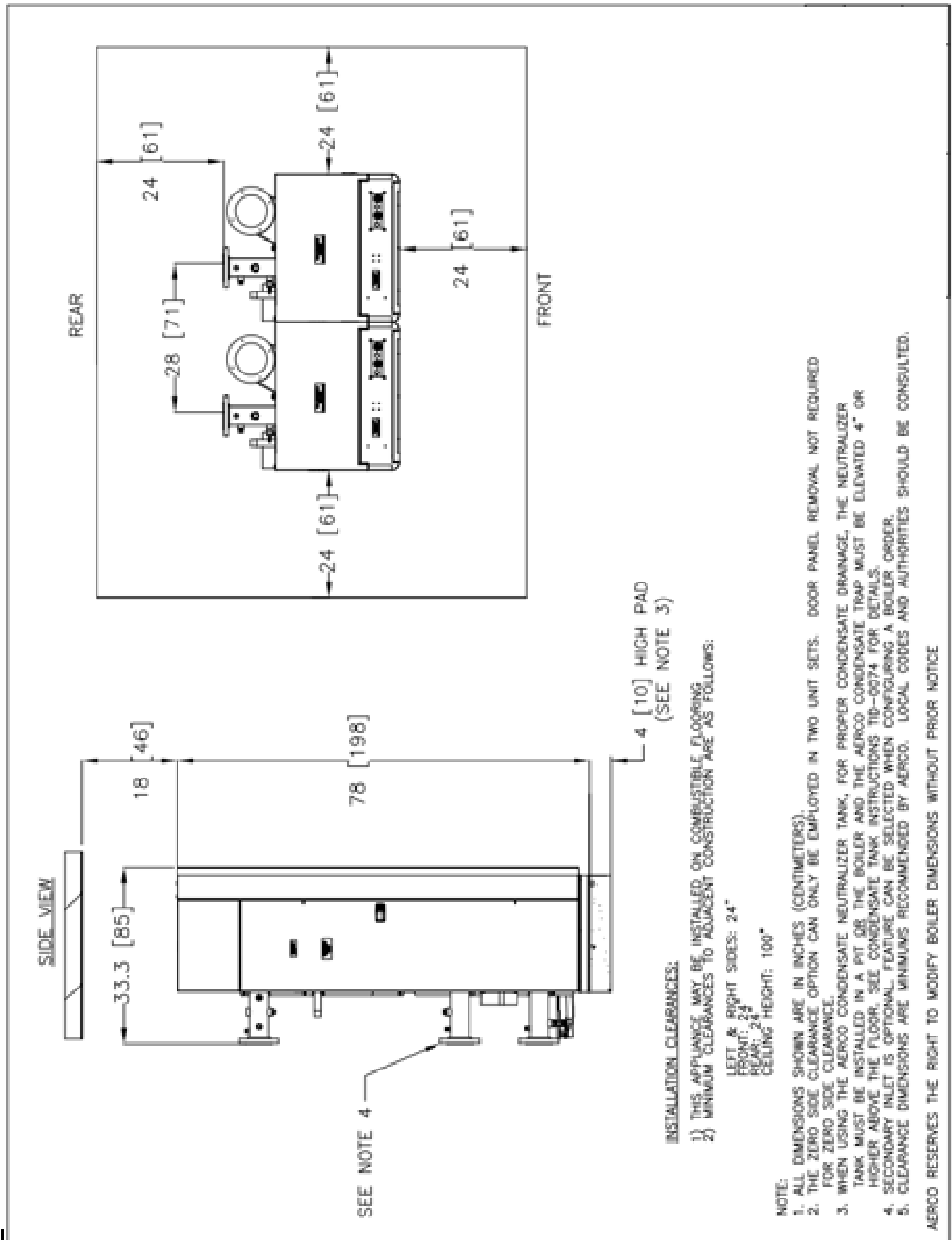

Benchmark 750/1000 Zero Side Clearance Drawing SD-A-872 rev D

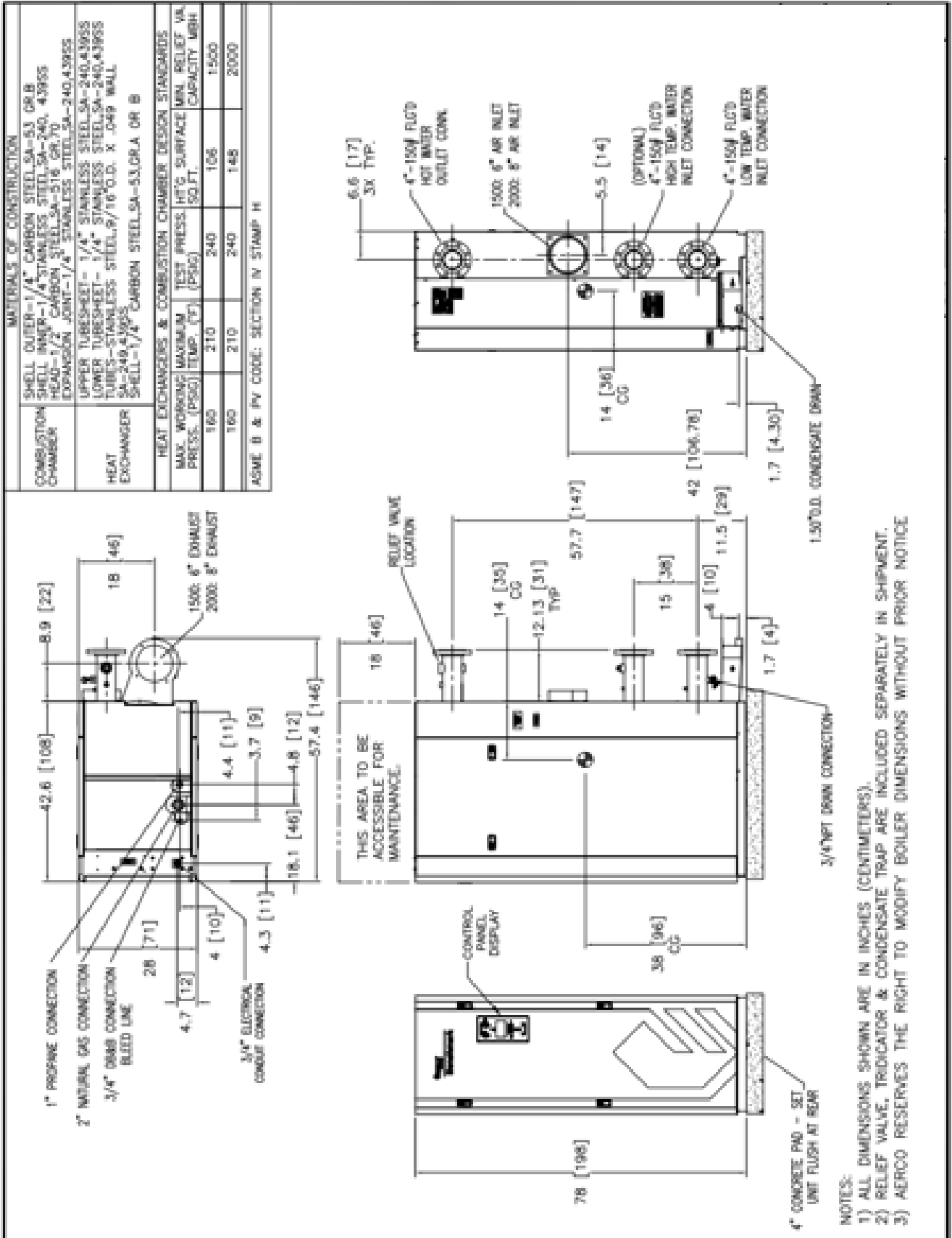

Benchmark 1500/2000 Dimension Drawing Number: AP-A-1036 rev E

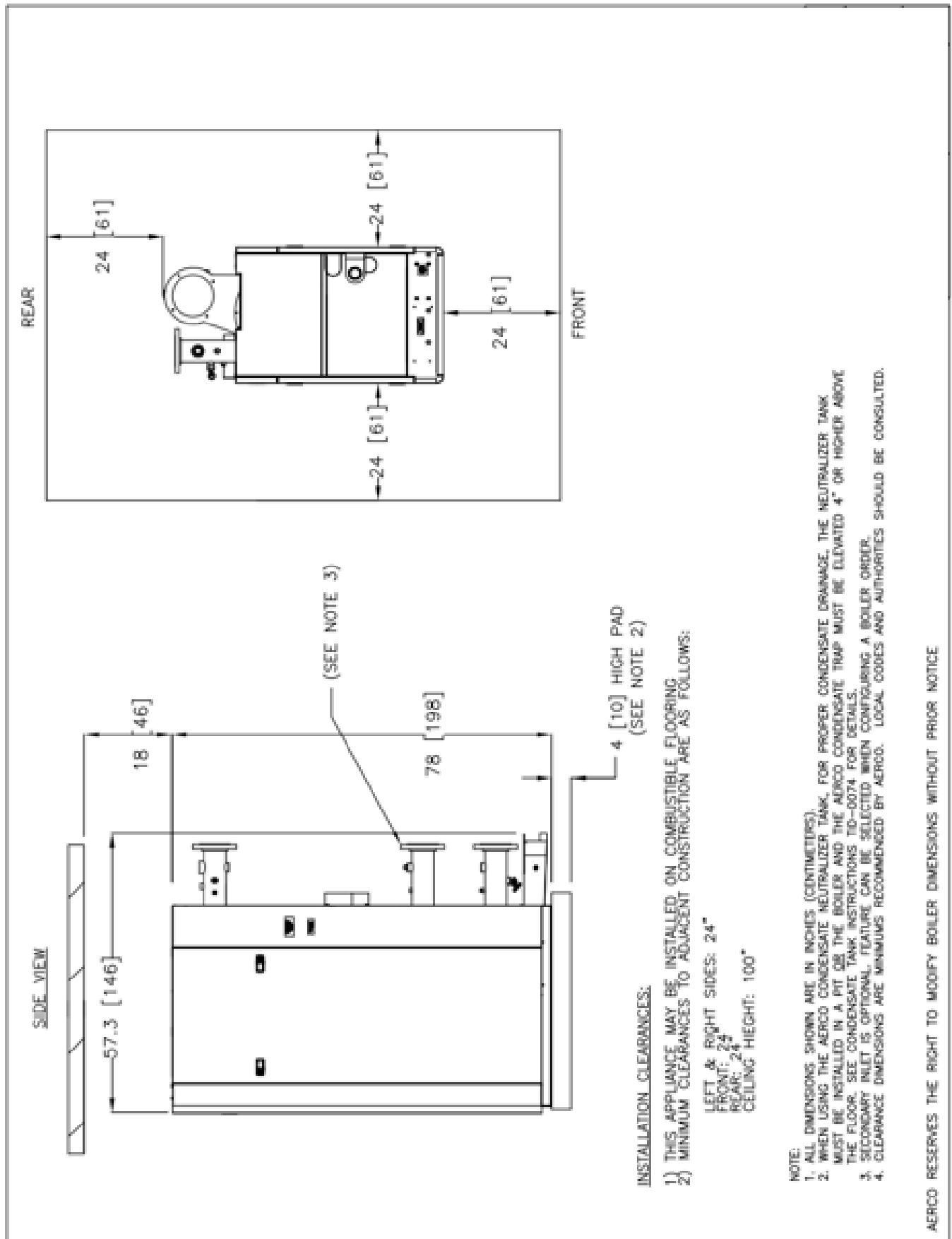

Benchmark 1500/2000 Clearance Drawing Number: SD-A-995 rev C

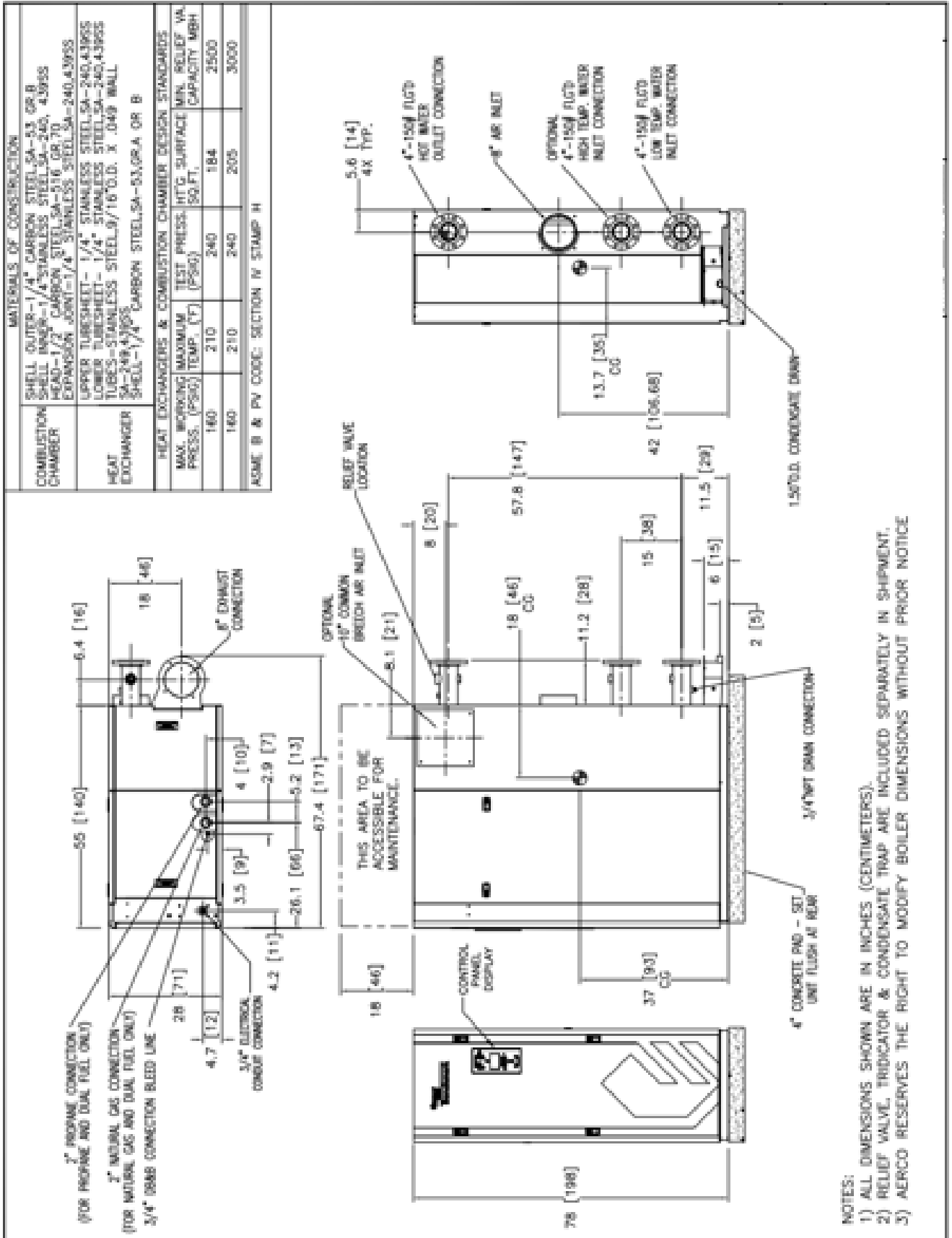

Benchmark 2500/3000 Dimension Drawing Number: AP-A-915 rev J

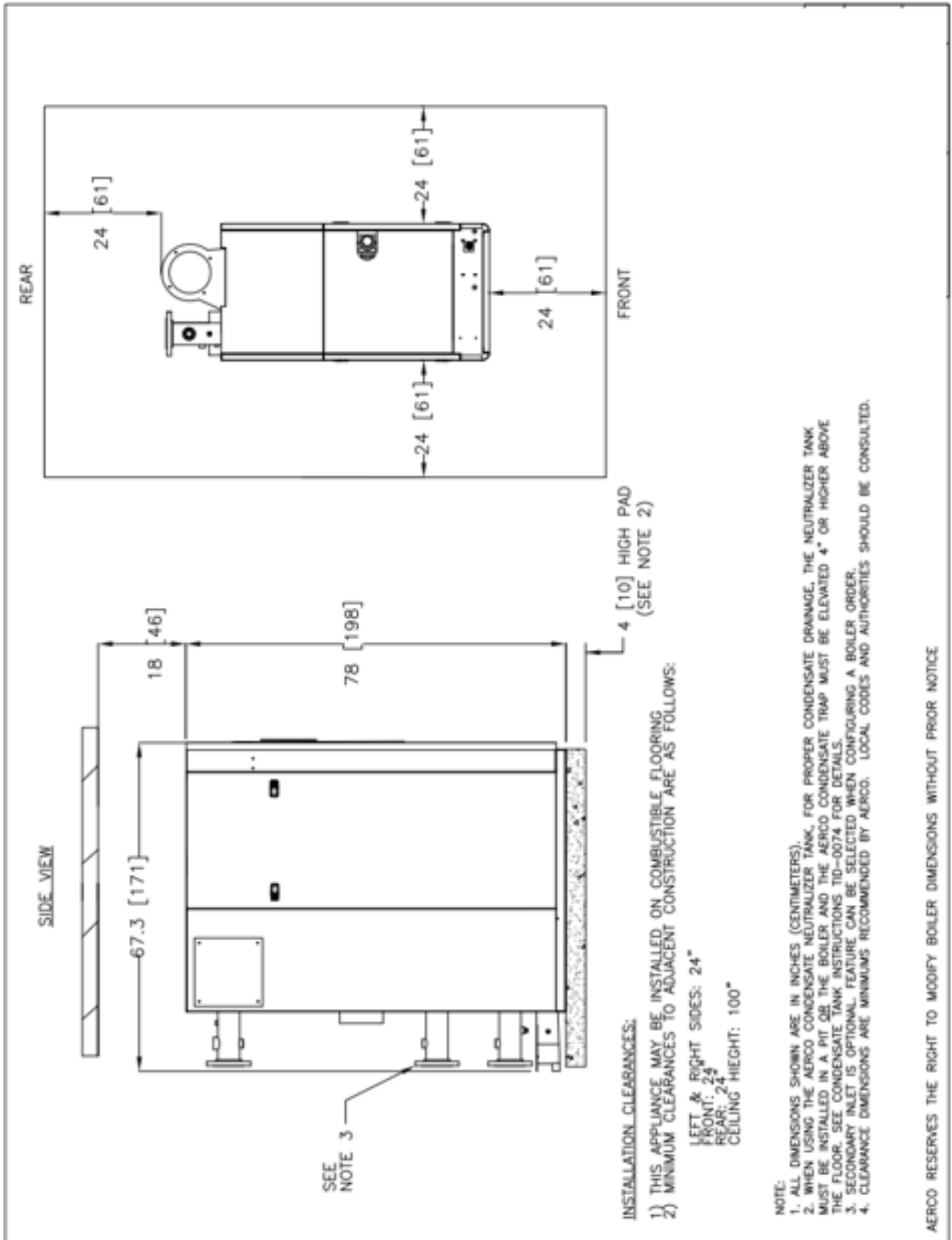

Benchmark 2500/3000 Clearance Drawing Number: SD-A-897 rev E

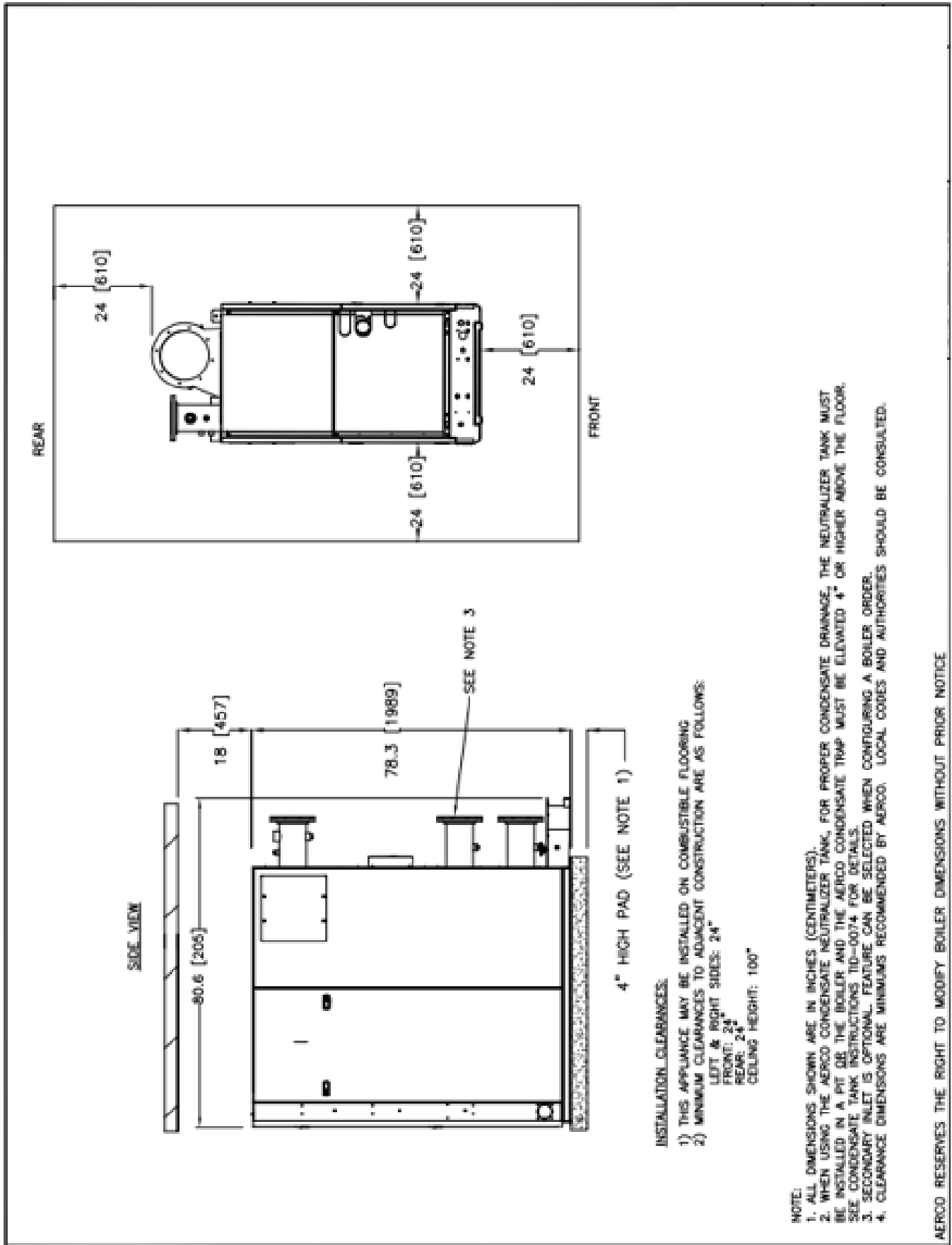

Benchmark 4000-5000N Clearance & Dimensional Drawing Number: SD-A-1195 rev C

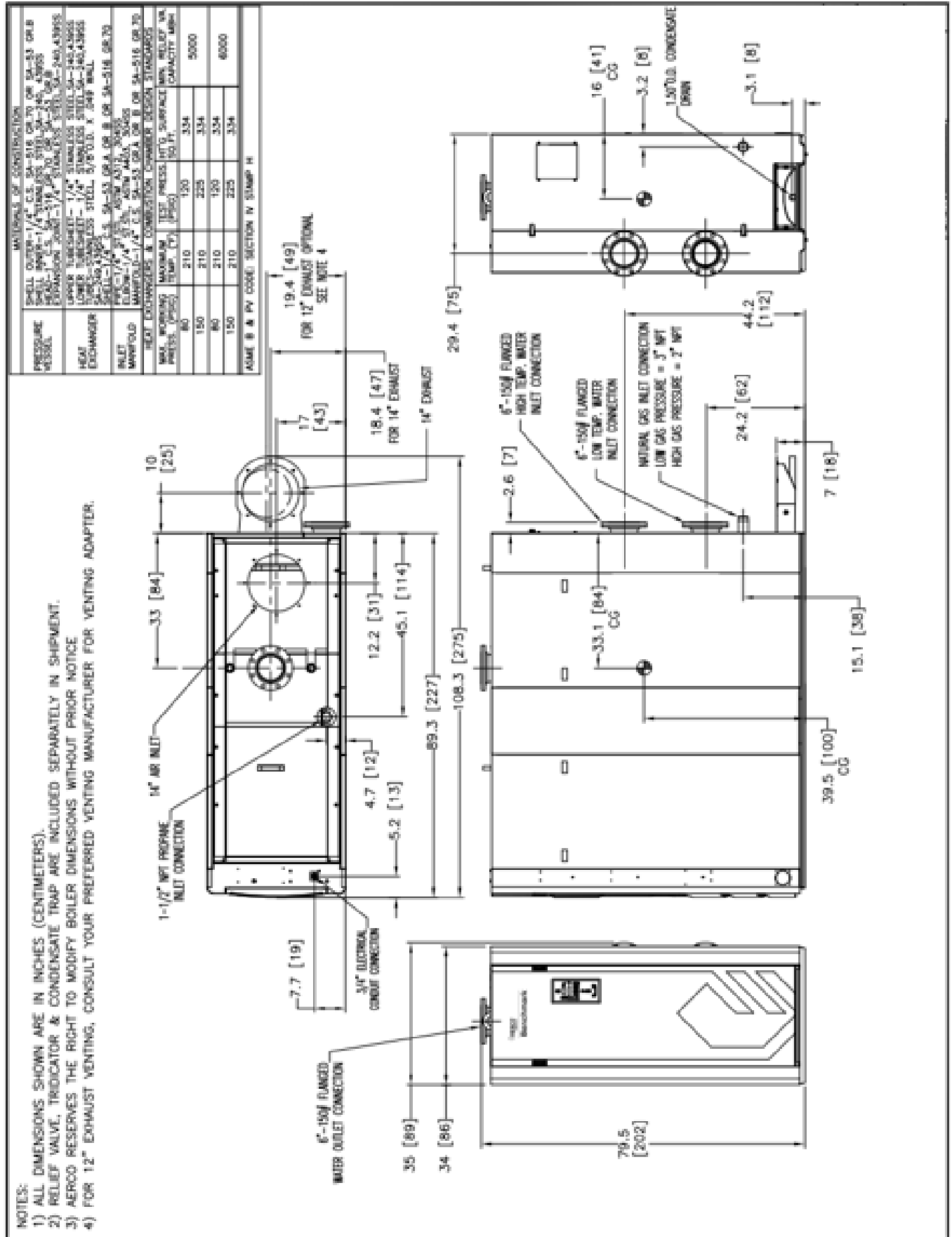

Benchmark 5000-6000 Dimension Drawing AP-A-1047 rev C

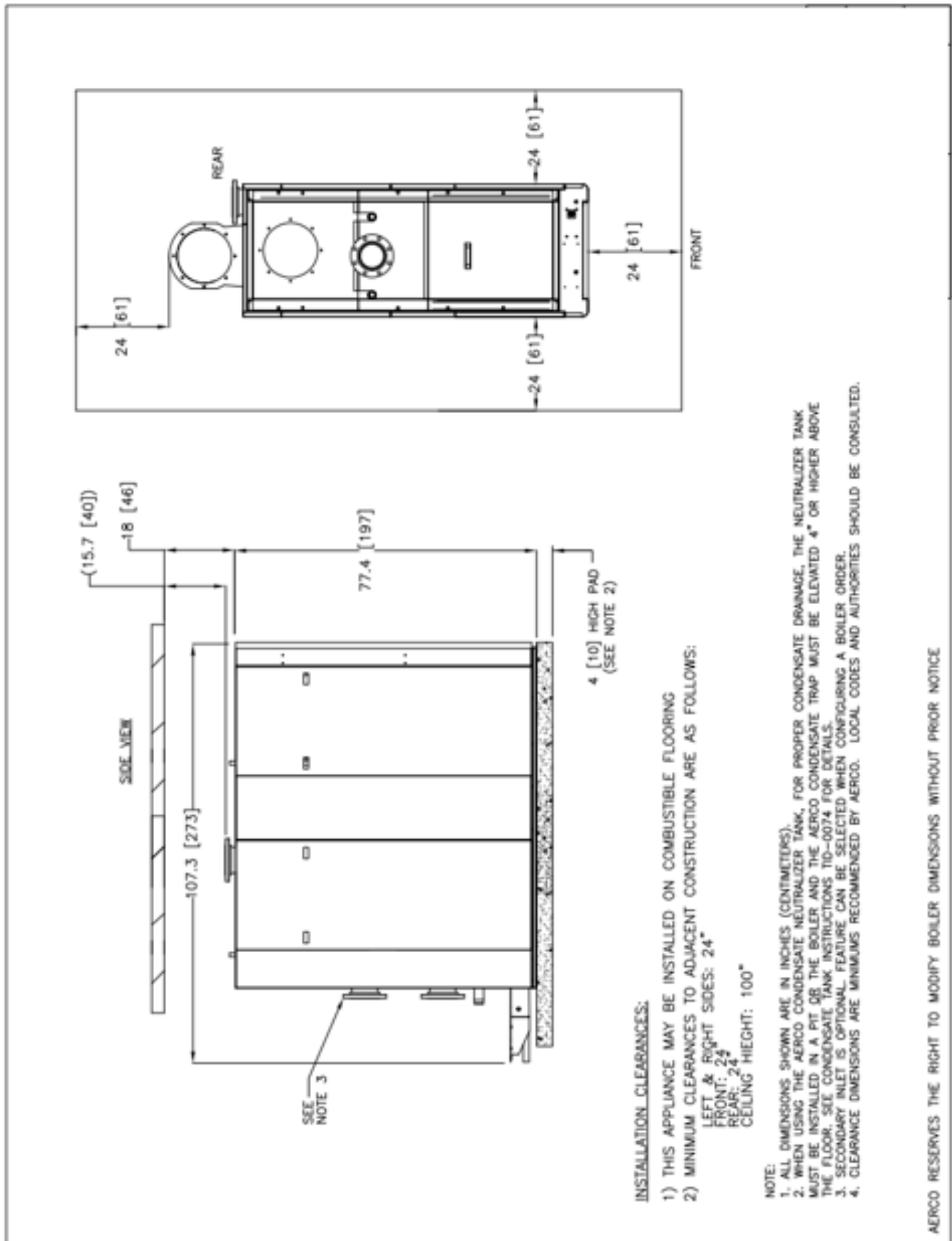

Benchmark 5000-6000 Zero-Side Clearance Drawing SD-A-920 rev G



© AERCO International, Inc., 2026